



M.T.H. HO Bi-Polar Electric Engine

(PS3)
ENGINEER'S GUIDE

Congratulations! You've just purchased the most feature-rich and technically advanced HO electric type locomotive ever produced! This highly detailed model includes a broader range of features than you'll find on any other HO scale locomotive, including operating pantographs, smooth performance from a three-scale-mile-per-hour crawl to full throttle; "cruise control" for steady speeds regardless of curves, switches and grades; built-in decoders for DCC and the M.T.H. Digital Command System (DCS); and a full range of sounds. If you're looking for modern motive power that's accurately detailed, smooth running, and a great deal of fun to operate, it doesn't get any better than this.

Operates on 18" radius curves with Code 70, Code 83 or Code 100 rails.



Passenger Station
Announcement

PLEASE READ THE MANUAL BEFORE USE AND SAVE
WWW.MTHHOTRAINS.COM

TABLE OF CONTENTS

UNPACKING YOUR ENGINE	4
Removing and Unwrapping Your Engine	4
What Else is in the Box?	4
PRODUCT OVERVIEW	5
Getting to Know Your Engine	5
Engine Diagram	7
SET-UP	7
Coupler Installation	7
Lubrication	10
FEATURES AND OPERATION	11
Pantograph Operation	11
Analog DC (standard DC power pack)	16
DCC Digital Command Control	18
DCS Digital Command System	24
SPECIFICATIONS	26
CARE AND MAINTENANCE	27
Troubleshooting Guide	27
HOW TO ORDER PARTS	33
SERVICE & WARRANTY INFORMATION	35
Service & Warranty Information	35
Limited One-Year Warranty	35

CAUTION: ELECTRICALLY OPERATED PRODUCT:

Recommended for Ages 14 and up. Not recommended for children under 14 years of age without adult supervision. As with all electric products, precautions should be observed during handling and use to prevent electric shock.

WARNING: When using electrical products, basic safety precautions should be observed, including the following:

Read this manual thoroughly before using this device.

- M.T.H. recommends that all users and persons supervising use examine the hobby transformer and other electronic equipment periodically for conditions that may result in the risk of fire, electric shock, or injury to persons, such as damage to the primary cord, plug blades, housing, output jacks or other parts. In the event such conditions exist, the train set should not be used until properly repaired.
- Do not operate your layout unattended. Obstructed accessories or stalled trains may overheat, resulting in damage to your layout. This train set is intended for indoor use. Do not use if water is present. Serious injury or fatality may result.
- Do not operate the hobby transformer with damaged cord, plug, switches, buttons or case.

This product may be protected by one or more of the following patents: 6,019,289; 6,280,278; 6,281,606; 6,291,263; 6,457,681; 6,491,263; 6,604,641; 6,619,594; 6,624,537; 6,655,640.

QUICK START GUIDE

Of course, you should read your manual over before running your engine. But if you just can't wait, choose how you want to run below and enjoy!! Now, after a few minutes, shut her down and read through your engineer's guide.

I USE A REGULAR DC SUPPLY...

Step 1: Unpack your Engine. (refer to unpacking instruction on pg 4)...

Step 2: Set the engine on the track ...

Step 3: Apply increasing **DC** voltage until she starts up and pulls out!

I'M A DCC OPERATOR....

Step 1: Unpack your Engine. (refer to unpacking instructions on pg 4)...

Step 2: Set the engine on the track ...

Step 3: Power up your DCC system...

Step 4: Select engine address 3 and press "F3" to start her up...

Step 5: Turn the throttle and head on down the pike...

I RUN DCS....

Step 1: Unpack your Engine. (refer to unpacking instructions on pg 4)...

Step 2: Set the engine on the track ...

Step 3: Power up your DCS system...

Step 4: Add the engine to your system and start her up...

Step 5: Turn the throttle and move out....

CAUTION: M.T.H. HO engines ***DO NOT OPERATE ON AC VOLTAGE***. Applying AC power to your locomotive could cause permanent damage and will void your warranty.

Please note, when making setting changes in DCS or DCC, such as address, please wait a minimum of 5 Seconds after removing power to insure the settings are stored in the engines memory. Reapplying power in less than 5 Seconds may result in losing the setting changes.

UNPACKING YOUR ENGINE

Removing and Unwrapping Your Engine

Carefully remove and unwrap the model on a soft surface. By nature, models with high levels of detail have some small fragile parts.

Carefully remove any foam packing pieces that may be surrounding the model.

Unpacking and Unlatching

Your MTH HO Little Joe is equipped with Remotely Controlled, Directionally Activated Operating Pantographs. When unpacking the engine the Remotely Controlled, Directionally Activated Operating Pantographs are latched in the down position. O unlatch the pantographs hold the pantograph at the sides of the base and pull up on the slider.



Removing and Re Installing Pantographs

When re-installing the pantographs, make sure that the sliding actuator blocks in the slots of the roof are pushed to the ends of travel. You may have power up the engine and make direction change for one of the pantographs.

Collapse the pantograph and align the 4 insulator details with the 4 holes in the roof. Also align the actuator tang with the slot in roof, while making sure that the actuator tang is situated between the two sliding actuator block in each slot in the roof.

Apply slight pressures so that the insulator details are inserted in the roof holes and the holes in the pantograph frames.

What Else is in the Box?

The following items are packed with your engine.

Engineer's Guide (1)

You probably know that since you're reading it.

Mechanical Kadee-Compatible Couplers (2) with mounting hardware

PRODUCT OVERVIEW

Getting to Know Your M.T.H. HO Locomotive

Key Features

Your new HO Diesel Engine is equipped with the exclusive M.T.H. Proto-Sound® 3.0 digital sound and control system. In plain English, this means your locomotive contains state-of-the-art electronics providing realistic digital sounds, precisely controlled speed in increments of 1 scale mile per hour, and much, much, more.

Compatibility

The Proto-Sound 3 system is universally compatible with track power and/or signal combinations including analog DC (regular DC power pack), DCC (NMRA Digital Command Control), or DCS (MTH Digital Command System). Simply set your Engine on the rails, apply any one of these power/signal sources, and move out! The Proto-Sound 3.0 system automatically senses the track environment and adapts accordingly. No hidden jumpers, switches, magic wands, or programming required!!! A vast array of realistic operation is automatic when the Engine is run on analog DC. You can expand access to features in a DCC environment. Experience the most your new locomotive has to offer in the simple to use yet powerful world of DCS. **To be clear, DCS is NOT a proprietary version of DCC, as some other manufacturers offer. DCS is a comprehensive layout control system designed with one primary goal: make model trains do amazingly realistic things using a simple and intuitive controller. We put the complexity on the inside, and the fun in your hands!**

Digital Sound

Your Proto-Sound 3 (PS 3) equipped Engine contains over 100 individual recordings. These recordings are played back dynamically at appropriate times to create a symphony of realism for your ears. Hear the diesel roar automatically intensify or lighten when speeding up or slowing down, listen to the sounds of brakes squeaking and squealing as you come to a stop, or enjoy the random conversations of railmen working as your model sits at idle. It's all there and it's incredible.

Your HO diesel includes built-in realistic horn sound effects, including forward (two blasts) and reverse (three blasts) signalling and crossing signal sounds, all available with one-touch control from a DCS controller or through any DCC controller capable of accessing up to F28.

Digital Control

In standard analog DC mode, your model still operates under digital control. The PS 3 advance speed control system converts track voltage into digital speed commands. Your model will run smoothly and consistently at any speed regardless of load, hills, or curves. If you are a DCC user, you'll quickly learn to appreciate the precision of our speed control and linear speed curve. DCS users will enjoy the added benefits of controlling speeds in increments of 1 scale mile per hour displayed on DCS controllers or easily changing acceleration and deceleration rates independently without any discussion of bits or bytes. **To be clear, DCS is NOT DCC.**

Lights

As you read on, you'll notice there are no instructions for replacing light bulbs in your diesel. That's because there aren't any. We use specially designed and controlled LEDs to create realistic lighting effects that occur automatically. Again, **NO PROGRAMMING!!** Just come to a stop and watch as the headlight dims automatically in accordance with rule 17. Of course, as you pull away, the headlight returns to it's fully bright, yet warm, glow. We even included a light in the cab so the engineers can see to do their jobs!

More...

In analog DC operation, just flip the track polarity or direction switch at any speed and watch your Engine gradually come to stop, turn on the appropriate directional lighting, and smoothly accelerate back up to speed. No other HO locomotive has features like these. There are so many more things to learn and enjoy about M.T.H. HO Engines, we could write a book. But, that's no fun. So, if you haven't already done so, flip to the Quick Start Guide and let's run your new engine!!

ENGINE DIAGRAM

Locomotive

Includes Remotely Activated Proto-Coupler™ and interchangeable magnetic coupler, both Kadee® Compatible

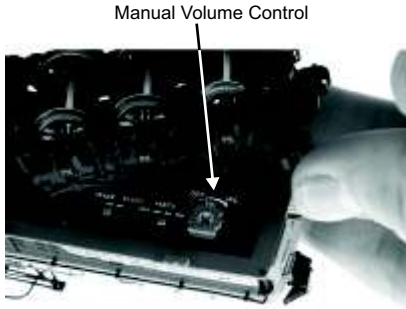
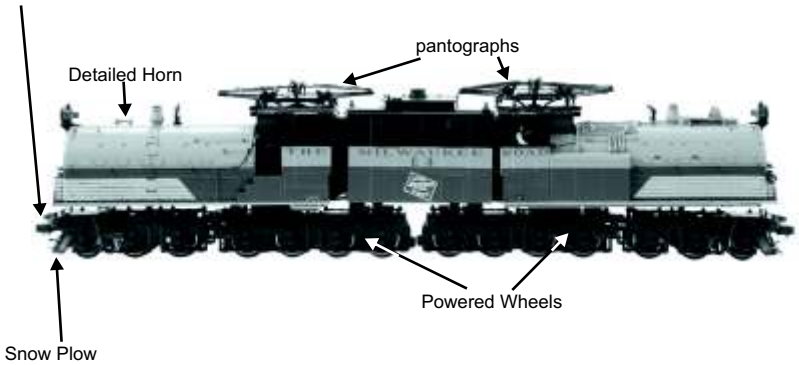

SET-UP

Installing The Mechanical Couplers

If you prefer the mechanical couplers over the remote control Proto-Coupler, remove the Proto-Couplers by following the steps detailed above and then install the included mechanical couplers or any other Kadee-compatible couplers by following the steps above.



SET-UP

Installing Couplers

A pair of shims (one for each coupler) are provided for use with the mechanical couplers. These shims should be placed between the coupler and the mounting pad on the pilot trucks. This sets the coupler to the proper mounting height.

Follow the steps below to remove the Remote Control Proto-Coupler and install the mechanical couplers.

Find a flat and level work surface suitable for disassembling your locomotive. Place the engine upside down in a cradle or a folded towel. This will stabilize the locomotive and help prevent the engine from rolling over during the operation.

1. Remove the 2 screws in the bracket that secures the electro coupler coupler.

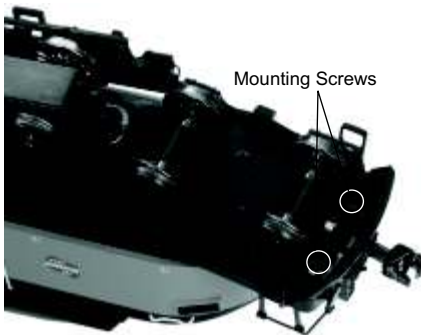

Identify & Remove Mounting Screws

2. Remove the bracket.
3. Remove the coupler by pulling it forward through the hole in the pilot.

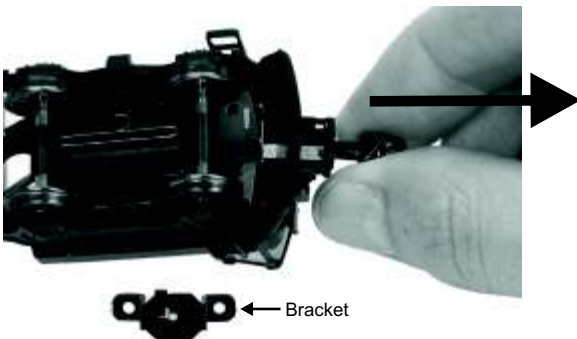

4. Place the clear shim on the coupler mounting pad as shown in fig. below

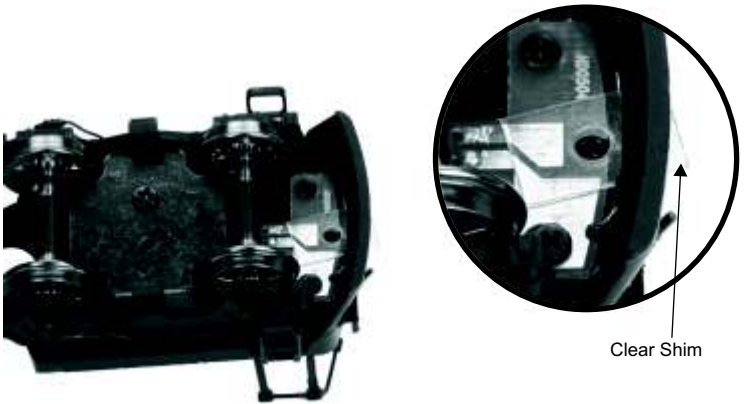

5. After assembling the mechanical coupler as shown below place the coupler in the pilot and attached with the screw provided.

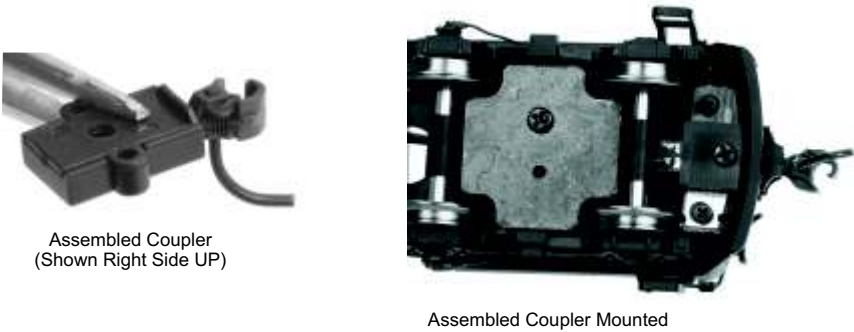

6. Using the coupler height gauge of your choice, check the coupler height and actuator arm setting using the gauge



7. Repeat the procedure for the 2nd coupler.

SET-UP

Lubrication

Using light machine or household oil, apply a very small amount to all axle points as shown.

Your gearbox is properly greased at the factory and probably never needs service however, if you run excessive hours pulling heavy loads, it's a good idea to remove the 2 screws from the gearbox cover and re-grease using M.T.H. gear grease or equivalent.

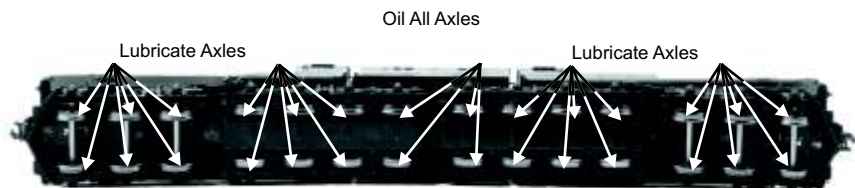

FEATURES AND OPERATION

The MTH HO Little Joe is designed to receive power through the wheels from the track or through the pantographs from an overhead catenary. Under the removable hatch in the center of the roof is a switch that selects the track or pantograph for power.



Pantograph or Track Power Switch

Operation with live catenary – One direction only!

When the selector switch is moved to the PANTO position, the power connection from the right side wheels is switched to the pantographs. This creates a limitation in that the locomotive still uses the left side wheels for the return path of the power. As a result the locomotive only can operate facing one direction. If the locomotive is turned 180 degrees on the track with the pantograph selected and the catenary energized, a short circuit may occur. This is dependent on the wiring of the layout.

Remotely Controlled, Directionally Activated Operating Pantograph Operation:

Normal Automatic Operation

In Normal Automatic Operation the pantographs will raise and lower with a change in the direction of travel of the locomotive.

It takes a few seconds for one pantograph to rise and then for the other to lower. It is recommended, but not necessary to stop the locomotive completely for each direction change and wait for the raise and lower cycle to complete before moving the locomotive.

This is mainly for visual effect and to help ensure that at least one pantograph is in contact with the catenary. This is especially important if you are using a live catenary to power your locomotive. Unless at least one of the pantographs is in contact with the catenary the engine will not receive power

The trailing pantograph will be the raised one and the leading pantograph will be the lowered one.

Note during a direction change, there will be a short period of time when both pantographs are raised. This mimics prototype operation to ensure there is no power interruption from the overhead catenary.

FEATURES AND OPERATION

DC Operation

In DC operation the pantographs will raise and lower with direction changes. In order to disable the automatic operation of the pantographs raising and lowering with each direction change, slide the AUTO - PANTO switch to the OFF position. Moving the switch to the ON position will restore the automatic operation.

The AUTO - PANTO switch is located under the removable hatch in the center of the roof.

DCS Operation with TIU and DCS Remote

In DCS operation the pantographs can be operated automatically or using the soft key commands in the DCS Remote they can be controlled by the operator.

NOTE: Software revisions of 4.1 or lower require a code upgrade to operate the HO Pantographs in the manual mode.

DCS Operation with DC Commander

The DCS Commander does not have the soft key option found on the DCS Remote. However, the operator using the following procedure and button combinations can remotely control the pantographs in the manual mode.

NOTE: Software revisions 1.3 and lower require a code upgrade to operate HO pantographs in the manual mode.

Press Button A2 to activate manual operation. The icon showing the word MAN will be displayed at the top of the LCD screen near the center. This indicated that the operator is controlling the pantographs manually.

Use the coupler buttons to select the pantograph to be controlled.

Front Coupler = Front Pantograph

Rear Coupler = Rear Pantograph

Labor / Rev Up - raises the pantograph selected

Drift / Rev Dn - lowers the pantograph selected

To return to Automatic / Direction change mode press the A2 button again.

FEATURES AND OPERATION

DCC Operation

Below are list of keys used for the operator to control the pantographs.

F10 toggles between Manual mode and Automatic mode.

F10 On - This enables the manual control mode and disables the automatic operation

F10 Off – This disabled turns manual mode off and returns to Automatic operation. This is the default mode.

F11 toggles the Front pantograph up and down*

F11 ON - Raises front pantograph.

F11 OFF - Lowers front pantograph (default)

F12 toggles the Rear pantograph up and down*

F12 ON - Raises rear pantograph.

F12 OFF - Lowers rear pantograph (default)

**Note – By default F11 and F12 are NOT enabled until the F11 or F12 buttons are pushed. If the F10 buttons are pushed to enable manual operation of the pantographs before the F11 or the F12 buttons are set to on, both pantographs will be lowered. Therefore it is recommended that F11 and F12 be enabled before pressing the F10 button. This will ensure that the pantograph(s) will remain in contact with the catenary. This is important when using an overhead catenary to deliver power, instead of the track. If both pantographs loose contact with the catenary when obtain power from an overhead pantograph, the engine will loose power and be unable to operate.*

Then after F10 has been enabled, lower the pantograph that you wish to be lowered.

Now either pantograph can raised or lowered using the F11 and F12 buttons.

F12 OFF - Lowers rear pantograph (default)

FEATURES AND OPERATION

Modes of Operation

There are 3 modes of operation with different levels of features accessible in each. We refer to them as analog DC, DCC, and DCS. Here's a little more explanation before we get into the features of each mode.

Analog DC

This is when there is nothing connected to the rails except a conventional DC power pack. These power packs generally have at least one variable output controlled by a throttle of some sort and a means of reversing DC polarity on the track to change the direction of your engine.

DCC or Digital Command Control

DCC is a popular digital command control scheme wherein the track power is also a digital control signal. That is, using a DCC controller, you can communicate with multiple engines and have them all moving at different speeds or moving in opposite directions on the same track at the same time. The power/command signal remains constant and engines are “commanded” to perform as desired. M.T.H. is new to DCC but, we recognize it's importance to many HO operators. So, we loaded our engine with more DCC features easily accessible to the operator than any HO engine ever built previously. You DCC guys are in for a real treat!

Please note, when making setting changes in DCS or DCC, such as address, please wait a minimum of 5 Seconds after removing power to insure the settings are stored in the engines memory. Reapplying power in less than 5 Seconds may result in losing the setting changes.

FEATURES AND OPERATION

DCS or Digital Control System

While the acronyms are close, this is about where the similarities between DCS and DCC end. Yes, they are both digital control systems however, M.T.H. DCS is NOT DCC. There are several proprietary versions of DCC on the market but friend, this is NOT one of them. M.T.H.'s DCS system is proven technology in the O and One gauge markets and now, we've brought its power and simplicity it to you.

First, the power signal in DCS is NOT the command signal. Next, DCS employs a fully functional bi-directional communication scheme opening a vast range of advanced features and yet, is so simple and intuitive, you can enjoy them! No programming tracks, bits and bytes, or conversion of binary to hexadecimal numbers here! To add an engine in DCS, just press "ADD ENGINE." After that, If you want to start your engine, just press "START UP" or, to turn the sound on or off, just press "SOUND." No combinations of letters or numbers to remember! We think you're really going to like this!

Please note, when making setting changes in DCS or DCC, such as address, please wait a minimum of 5 Seconds after removing power to insure the settings are stored in the engines memory. Reapplying power in less than 5 Seconds may result in losing the setting changes.

Analog DC

Not much explanation is required here, and that's exactly why you run your trains this way! Here's the good news, even if you like to keep it simple, your MTH HO engine is packed with cool sounds, lights, and operating features, that you're going to love.

Running the Engine

Set the engine on the rails, and apply DC power. Refer to the Set-Up section of this guide for instructions on how to lubricate the chassis.

As you increase power, at about 6 volts, the lights and sounds will come on. Keep going on up to about 8 and she'll move out! About 16 volts DC is adequate for prototypical speeds however, your engine can handle up to 24 volts DC if you feel the need for speed!

Changing Direction

If you flip the direction (polarity) switch on your power pack while the engine is moving, it will gradually slow to a stop, and slowly accelerate back up to speed in the opposite direction. This is an exclusive feature of MTH engines that we're sure you'll enjoy. You can also change direction the old fashioned way by reducing throttle until the engine stops, flip the direction switch, and then increase throttle again. Either way is OK, we just thought a graceful transition from any speed would be cool.

If you switch track polarity too slowly, the engine may stop abruptly and not move in the reverse direction. This is normal. There is a feature we call “anti-jack rabbit” that prevents the engine from taking off at high speeds when high voltage is applied to the track instantly. Some direction switches have a “dead” spot where the power is completely off during polarity changes. This can invoke the anti-jack rabbit feature. The solution is to flip the direction switch more quickly. Don't worry you won't hurt the engine.

Speed Control

Your engine is equipped with speed control. This feature is always active, even in analog DC mode. Basically, your engine constantly measures track voltage and converts this to a digital speed command. You should notice the speed remains constant up and down grades, around curves, and with varying loads. This is no accident. You've got the most precise speed control system available today.

Sounds

In this mode, sound are pretty much automatic. If you're moving, you'll hear diesel sounds.

When your sitting at idle, there may be some maintenance done. You could hear someone calling for help on the radio. Don't worry, all of this and more is just a normal part of everyday operations.

When your moving at a pretty good clip and you reduce the throttle quickly, you may hear the brakes squeak and squeal as the engineer applies them. Of course, they'll stop when the engine does.

If things get too noisy, just locate the sound volume pot under the rear roof adjust the volume from maximum down to off, whatever suits you. Turn it counterclockwise to reduce the volume or clockwise to increase it. Refer to page 7 for volume pot location.

Lighting

Now, this is an illuminating section (we couldn't resist). Your model is equipped with a headlight, marker lights, operating ditch lights, and cab interior light.

The first thing to know about the lighting is there aren't any bulbs. It's all LEDs so, if you look for a section on how to replace them, you won't find it. You should never have to.

As with sounds, in analog DC mode, lighting operation is fully automatic. They're always on and behave appropriately.

The headlight functions under rule 17 and dims when stopped for a time or while backing up. Of course, just as you begin to move forward, it goes bright to show the way.

The cab light is always on so the engineer can always see clearly.

DCC Digital Command Control

Now, if your operating in this mode, you may very well know more about DCC than we do so, we're going to stick to telling you about our engine in this operating environment. First of all, in DCC mode, we brought all the features of analog DC along and of course, added to them. Your new engine has more user features than any DCC engine ever built. Some of them are even ahead of the world of DCC!!

Running the Engine

Set the engine on the rails, and apply DCC power. Refer to the Set-Up section of this guide for instructions on how to connect the boiler and tender.

The first thing you will notice is the engine does absolutely nothing! Don't panic. This is by design. M.T.H. HO engines never do anything in command mode until told to do so, regardless of what brand DCC controller you use. In this way, you could have a fleet of M.T.H. HO engines on the rails and they will remain shutdown until you command them to start up.

F3 Start up/Shut Down

Select engine address 3 (factory default), press the F3 (Start Up/Shut Down) key, and your engine will start-up. Lights, sounds, ACTION!!! Roll the throttle and away you go. Our models are compatible with 14, 28, and 128 speed steps. We strongly recommend 128 because in this mode, speed steps correspond directly to scale speeds. That is, speed step 10 = 10 smph, speed step 47 = 47 smph, etc. You get the idea. When your done, press the F3 key again, your engine will shut down.

To be clear, pressing F3 when the engine is shut down will start it up. Pressing F3 when the engine is started up will shut it down. Pretty clever, eh?

DCC Programming –

Programming on the Program Track –

Although many DCC systems have a feature for programming locomotives on a dedicated program track, the track voltage on the program tracks are not high enough for reliable operation of the MTH HO Locomotives.

Program must be done on the main track. An isolated section of track is recommended to insure that the DCC system is communication with the locomotive you wish to program and only with the locomotive that you wish to program.

Programming on the Main

Detailed instructions for programming on the main can be found on the MTH main web site. www.mthtrains.com

In the window titled **Search This Site** enter the letters DCC and then click on the go button. Now click on the **Protosound 3.0 Troubleshooting**.

You will now see a list of categories for troubleshooting and programming assistance. Click on the section that provides assistance for your brand of DCC system. The instruction will guide you step by step through the programming process.

Sounds

As in analog DC mode, the default sound arrangement is automatic. So, you can just run your engine and its sounds will follow the action. But, you operate in DCC for a reason. You want access to more features, right? Well, depending upon the capabilities of your DCC controller, you now have access to a range of sound features including bell, horn, PFA, engine sounds on/off, master volume, Doppler, and more.

Here's a brief description of commonly used sound features.

F1 Bell

Toggles bell sounds on/off. Listen to the last half ring of the bell when it stops!

F2 Horn

Blows the horn, for as long as it's on. There are several different ending signatures depending on how long you hold the button down. Check it out!

F3 Start-up/Shut-down

F4 PFA

PFA in MTH lingo stands for passenger and freight announcements. Since your engine provides passenger service, you'll hear passenger station sounds.. PFA is a very popular sound feature that's a staple in almost all MTH products. We had to give you this!

There are 4 sound sequences or segments in PFA. You advance through them at your command. Each segment has a minimum time of ~10 seconds but more sounds play the longer you listen.

When running the engine, simply press the F4 key to activate PFA. When you bring the engine to a stop, the arrival sequence will play. You can remain in this segment as long as you like.

Press F4 again, and advance to disembarking sequence. Again, you can listen to this sequence as long as you like.

Press F4 again, and advance to the embarking sequence. Again, you can listen to this sequence as long as you like.

Press F4 again, and advance to the departure sequence. After a short period the engine will automatically pull out and resume the speed and direction of when you entered the feature. The bell will ring for a short while and then turn off automatically.

F6 Master Volume

This command cycles through 9 volume settings from off to max. Each press advances to the next cycle. Unlike the F6 engine sounds command, when the master volume is set to off, no sounds can be heard.

If your DCC controller has more F functions, you can access even more features. Check out the complete list in the chart at the end of this section.

Lighting

As with other feature categories, lighting in DCC mode operates just like analog DC with regard to rule 17, constant brightness and directional behavior. See that section for details. DCC provides some additional control to suit your preferences.

F0 Headlight

Toggles the headlight on/off.

F5 Lights (except headlight and taillight)

Toggles all lighting on/off, including Marker and Classification LED's. When on, all lighting behaves automatically as described elsewhere. When F5 is off, all lighting is off.

More DCC

Okay, we've walked you through the basic features and functions available in DCC (F0..F8) but, there is much, much more. In fact, we've filled up functions F9 through F28. Some controllers are available today that provide easy access to F9 through F12 however, we don't know of any that allow you to press a button for F13 through F28. When the DCC controllers expand to include these functions, your MTH HO engine will be waiting. Here is a list of the F9 through F28 functions present in your engine with a brief description of how they work.

F9 Coupler Slack

When sitting still, arms the system to play the sound of coupler slack being pulled out as the engine moves.

F10 Panto Auto/Manual

F11 Front Panto Up/Down

F12 Rear Panto Up/Down

F13 Reverse Signal

Plays 3 short horn toots to signal the engine is moving in reverse

F14 Forward Signal

Plays 2 short horn toots to signal the engine is moving forward

F15 Grade Crossing

F16 One Shot Doppler

F17 Extended Start Up

Plays a longer, more detailed and realistic start up sound sequence.

F18 Extended Shut Down

Plays a longer, more detailed and realistic shut down sound sequence.

F19 Rev Up

Increases the diesel revs. Each press of F15 runs the revs up another notch. There are 8 settings.

F20 Rev Down

Decreases the diesel revs. Each press of F16 lowers the diesel revs a notch.

F21 Eng Sounds On/Off

F22 Short Horn Blast

Plays a single short horn blast so you can make up your own signal patterns.

F23 Coupler Close

Plays the sound of 2 couplers crashing together and closing.

F24 Feature Reset

Resets the engine back to factory defaults with the exception of the address.

F25 Idle Sequence 1

Plays what we call idle recipes 1 through 4. These sound sequences play randomly when the engine is at idle but if you have these F functions, you can trigger them whenever you like.

F26 Idle Sequence 2

Plays what we call idle recipes 1 through 4. These sound sequences play randomly when the engine is at idle but if you have these F functions, you can trigger them whenever you like.

F27 Brake Sounds On/Off

Toggles brake sounds between auto and off. They are on by default but you can turn them off.

F28 Cab Chatter On/Off

Toggles random voices between auto and off. They are on by default but you can turn them off.

DCC “F” FUNCTION LIST

F Key Function

- F0 Headlight (also toggles Ditch Lights)
- F1 Bell
- F2 Horn
- F3 Start-up/Shut-down
- F4 PFA
- F5 Lights (Lights (except headlight and taillight))
- F6 Master Volume
- F7 Front Coupler
- F8 Rear Coupler
- F9 Coupler Slack
- F10 Panto Auto/Manual
- F11 Front Panto Up/Down
- F12 Rear Panto Up/Down
- F13 Reverse Signal
- F14 Forward Signal
- F15 Grade Crossing
- F16 One Shot Doppler
- F17 Extended Start Up
- F18 Extended Shut Down
- F19 Rev Up
- F20 Rev Down
- F21 Eng Sounds On/Off
- F22 Short Horn Blast
- F23 Coupler Close
- F24 Feature Reset
- F25 Idle Sequence 1
- F26 Idle Sequence 2
- F27 Brake Sounds On/Off
- F28 Cab Chatter On/Off

CV Description (Program On Main, POM Only)

- 1 Short Address 1-127
- 3 Acceleration Rate 1-25 smph / sec (4 smph / sec is the default)
- 4 Deceleration Rate 1-25 smph / sec (4 smph / sec is the default)
- 17 & 18 Extended Address (upper bits must be set to 1)
- 29 Enter 38 to set extended address to engine cab number or
Bits 5 = ext.addr; bit 1 = speed / direction method
- 49 Short Address (controllers that prohibit addr POM)
- 50 & 51 Extended Address (controllers that prohibit addr POM)
- 55 Reset - Sends value = 55 to CV55 on address 55 (Do not assign
address 55 to any engine as an engine address)

DCS Digital Control System

As you may have gathered by now, DCS is an M.T.H. exclusive Digital Control System that provides easy access to dozens and dozens of features in our models. We developed DCS to provide a powerful and advanced model train control system that was simple and enjoyable to use. We've accomplished that goal. DCS further expands the features available far beyond that of DCC. After all, in DCC, we only had a limited number of "F" commands to fill.

As with DCC, we'll leave the detailed "how-to" system explanations to the DCS system manuals. What you should know are all the cool features your engine has built-in, waiting for you to experience.

Running the Engine

Once the DCS system is connected to your track and powered up by a DC Power Supply (even though DCS can be controlled by AC and DC power supplies, your M.T.H. HO locomotive will ONLY run on DC power), you simply place your engine on the rails, press "ADD ENG" and the system will scan the track and automatically upload your engine into the controller. At this point, you can press "START UP", roll the throttle and pull out! That's it!

Speed Control

DCS engines are controlled in scale miles per hour (smph) and increments of one. So, that means if you dial up 10, your engine will smoothly accelerate to 10 smph. There is no need to select a speed step setting, there's only one precise linear control at scale speeds. See, powerful yet simple.

Sounds

Independent Volume Settings

Using DCS, you independently adjust the bell, horn, engine, and accent sounds volume. This is like a mixer so you can set up the engine fit your specific tastes and sense of realism. Oh, they all move relatively up or down with the master volume settings.

Doppler Loop

You can either press the Doppler button on the remote to activate what we refer to as "one-shot" Doppler or, using DCS, you can program a Doppler loop that will peak at the same point on your layout, over and over.

Custom Sounds

You can fire any of 10 individual sound bites pre-loaded into your engine. These are typically, diesel idling sounds. Each one at the press of a single button. You can also make voice or other audio recordings and play them back on command with ease.

Proto-Dispatch

Press the “MIC” (microphone) button on your DCS remote and speak. Your voice will be digitized and played out of the model in real-time. Talk about station announcements!

Proto-Cast

Another MTH exclusive, you can connect any audio source with a line output to the DCS TIU and send music, train sounds, or anything you like down the rails to be played through the engine as it moves along the track. Your holidays may never be the same!

Lighting

As with everything in DCS, this becomes a little more than obvious. Pressing the “HEADLIGHT” button turns off the directional headlight and reverse light (if equipped). Pressing the Interior light will turn off the cab interior light.

SPECIFICATIONS

Electrical	Input Voltage	0 - 24 VDC
	Current Draw (lights, sounds)	~230 – 650 mA
	Lighting	LED - Rule 17
Operating Modes	Analog DC	Yes
	DCC - Digital Command Control	Yes
	DCS - Digital Control System	Yes
Default Addresses	DCS	1
	DCC short	3
	DCC extended	Cab No. or 3333

US PATENTS

US 6,457,681	Oct. 2, 2002
US 6,619,594	Sept. 16, 2003
US 6,655,640	Dec. 2, 2003

CARE AND MAINTENANCE

HO Troubleshooting Guide

The following Guide will help you trouble shoot your M.T.H. HO engine. This guide is broken up into the three operating modes of the engine Analog DC, DCC, and DCS

Analog DC

Start-up	Solution
When I apply power to the track my engine doesn't do anything. No lights, no sound, no nothing.	Check to see if that section of track has power. Use a voltmeter or a lit passenger car.
	Slide the engine a couple of feet in either direction, you may have a bad track section
	Have you got that section electrically isolated with a toggle switch or other device?
Sound	Solution
I have no sound from my engine, but my lights are on and it moves just fine.	Check the volume pot on your locomotive. Full CW = Max volume
There's a crackling sound from my engine	Check to see if a screw or some other material hasn't lodged itself in the underside of the engine body.

Analog DC

Lights	Solution
One of my lights is out	Most likely you had been running the engine in DCC or DCS mode and toggled that light off. Put it back into one of those modes and turn that light back on. The engine will remember that when you run it again in Conventional DC.
None of my lights are on	Could be the same reason as “One of my lights is out”
	Is the engine getting power? Check to see if there is voltage on the track or move the engine a few feet in either direction.
Motion	Solution
When I apply power to the track my engine starts up (lights and sound) but it won't move	Lower the track voltage then raise it again. The engine should start moving. If you apply greater than 9VDC quickly the engine will just set there. Lowering it below 9VDC then raising it will get the engine moving
My engine hesitates at slow speeds	An engine may do this right out of the box if it has not been lubricated. Follow the lubrication instructions. Now go ahead and run it.
	New engines even after they are lubricated may take a little bit to get everything run in. Be a little patient and let it run for a bit. It should clear up shortly after lubricating and running

DCC

Start-up	Solution
When I apply power to the track my engine doesn't do anything. No lights, no sound, no nothing.	Did you press F3 yet? F3 on your DCC handheld will start your engine up.
	Check to see if that section of track has power. Use a voltmeter or a lit passenger car, not your tongue.
	Slide the engine a couple of feet in either direction, you may have a bad track section
	Have you got that section electrically isolated with a toggle switch or other device?
Sound	Solution
I have no sound on my engine, but my lights are on and it moves just fine	You may have it turned off. Repeatedly press F7 to cycle through the volume levels (there are 9 levels, 0-max)
When I run Doppler I can hear the Doppler shift but then the engine sounds fade out and I can't get them back	This is normal. You will need to press the F12 button again to turn Doppler off. Your engine sounds will now return to normal

DCC

Lights	Solution
One of my lights is out	Check your F keys. F0 is the headlight (also controls the Back-up light) and F5 will toggle the Cab light
None of my lights are on	Could be the same reason as "One of my lights is out"
	Is the engine getting power? Check to see if there is voltage on the track or move the engine a few feet in either direction.
Motion	Solution
My engine hesitates at slow speeds	An engine may do this right out of the box if it has not been lubricated. Follow the lubrication instructions. <u>Now go ahead and run it.</u>
	New engines even after they are lubricated may take a little bit to get everything run in. Be a little patient and let it run for a bit. It should clear up shortly after lubricating and running
PFA	Solution
I hit F4 to start PFA but the engine just keeps ringing its bell, that's all it'll do	Bring the engine speed to 0. You will now hear the station arrival sounds (pretty cool, huh?). Pressing F4 will cycle you through the PFA sequence (check out the PFA section of the manual for more)
Why does my engine run away all by itself after the PFA is over?	This is normal. The engine will leave the station at the same speed it entered (when you hit F4 the first time). You can not control the speed of your engine while it's leaving the station, until the bell stops ringing.
Shut Down	Solution
Okay, I give up. What do I have to do to shut it down?	Well, you can either remove power from the track or press F3 again

DCS (Remember, it's NOT DCC)

Start-up	Solution
When I apply power to the track my engine doesn't do anything. No lights, no sound, no nothing.	This is normal. You have to hit the Start-Up button.
	Check to see if that section of track has power. Use a voltmeter or a lit passenger car, not your tongue.
	Slide the engine a couple of feet in either direction, you may have a bad track section
	Have you got that section electrically isolated with a toggle switch or other device?
I get an error when I hit Start-Up	Have you recently changed the engine address?
	Check if there is power on that section of track the engine is sitting on (there has to be power for the signal to get to the engine and for the engine to be able to hear it)
	If you have two engines on the track they both may have the same address. Take one of them off the rails and try it again
DCS is polarity sensitive when powered by a DC power supply.	Check the polarity of the DC power supply connected to the Fixed 1 or Fixed 2 Inputs. Shut down power, reverse the inputs and repower DCS. Hitting the startup button the DCS remote should start up the locomotive.
Sound	Solution
I have no sound on my engine, but my lights are on and it moves just fine	You may have it turned off. Repeatedly press VOL + to bring the Master Volume up
	Did you turn off the ENG Sounds? Press the ENG SND button on your DCS controller.
	Check that you haven't lowered any of the independent engine volumes (Eng Sounds, Bell, Whistle, or Accent)
When I run Doppler I can hear the Doppler shift but then the engine sounds fade out and I can't get them back	This is normal. You will need to press the Doppler button again to turn Doppler off. Your engine sounds will now return to normal

DCS (Remember, it's NOT DCC)

Lights	Solution
One of my lights is out	Check that you haven't turned it off with the DCS controller. You have independent control over lights on your engine
None of my lights are on	Could be the same reason as "One of my lights is out"
	Is the engine getting power? Check to see if there is voltage on the track or move the engine a few feet in either direction.
Motion	Solution
My engine hesitates at slow speeds	An engine may do this right out of the box if it has not been lubricated. Follow the lubrication instructions. Now go ahead and run it.
	New engines even after they are lubricated may take a little bit to get everything run in. Be a little patient and let it run for a bit. It should clear up shortly after lubricating and running
	Check to see if you have any kind of binding on the side rods. There may be a chunk of your favorite, perfectly scaled pine tree stuck in there.
PFA	Solution
When I enter PFA all that happens is the bell rings. What do I do?	Press the DIR button. Your engine will stop and begins the arrival sequence. Pressing the DIR button will cycle you through the next 3 PFA sequences
Why does my engine run away all by itself after the PFA is over?	This is normal. The engine will leave the station at the same speed it entered (when hit the PFA button). The speed setting can be changed after the bell stops ringing.
Shut Down	Solution
Okay, I give up. What do I have to do to shut it down?	Well, you can either remove power from the track or press or press Shut-Down. Button on the DCS Remote

HOW TO ORDER PARTS

How does it work?

Use Product Search to look up the item and view its exploded view.

The screenshot shows the MTH website's product search interface. At the top, there is a navigation bar with the MTH logo and a 'Product Search' link. A sidebar on the left contains a list of navigation options: Shopping, Catalogs, Shows, Club Info, Service, Shipping, Video, and Product Locator. The main content area features a large advertisement for the 'Premier O Scale F40PH Diesel Locomotive'. The ad includes an image of the locomotive, the text 'CHECK OUT THE VALUE: Premier O Scale F40PH Diesel Locomotive', and a 'CLICK HERE TO LEARN MORE!!' button. Below the ad, there are two columns of text: 'The Premier Line F40PH O Scale Diesel Max Streamer, Check out the details by CLICKING HERE.' and 'How does it look? See the product FREE! CLICK HERE to learn more.' At the bottom of the ad, there is a row of logos for various MTH products: REALTRAX, SCALETRAX, and others. A 'Home Page' link is visible below the logos, and a 'MEMBERSHIP' button is at the very bottom.

The screenshot shows the MTH website's advanced search interface. At the top, there is a navigation bar with the MTH logo and a 'Product Search' link. A sidebar on the left contains a list of navigation options: Shopping, Catalogs, Shows, Club Info, Service, Shipping, Video, and Product Locator. The main content area is titled 'Search for a Product by Item Number'. It includes a search box and a 'Search by Item Number' button. Below this, there is a section for 'Advanced Search'. The text reads: 'Advanced search is designed to help you find what you want based on what you know. It is suggested that you enter search criteria in only two or three of the fields at a time. (ex. Catalog 1900 Volume 2 and Roadname Amtrak) This will give you a list of items where you should find what you are looking for. In some cases product images depicted online may not be production models. All item's features, prices, graphics and content are subject to change after publication.' Below this text, there are several search criteria fields: 'Begin with one of our catalogs:' with a dropdown menu showing 'No choice'; 'Start with a product class:' with a dropdown menu showing 'No choice'; 'Add one of our product lines to your search:' with a dropdown menu showing 'No choice'; 'Add a description:' with a text input field; 'Add a Roadname:' with a text input field; and 'Add a Cab Number:' with a text input field. At the bottom, there is a 'Search with Advanced Search' button.



HO 2001-1
CSX
MTH HO
Original MSRP \$299.95
2008 HO Volume 3 Catalog #49

SD70AC Diesel Engine w/Proto-Sound® 3.0 - C00

Case nos. #813, #816 & #829

Product Details

The SD70AC is EMD's Most Efficient locomotive for the Mainline. While designed to meet the Environmental Protection Agency's Tier-2 emissions requirements, that took effort on January 1, 2005, this replacement for the SD70AC also has a higher purpose: to recapture the lead in both American locomotive sales that EMD lost to General Electric in 1987.

Under the hood beats a third-generation model T10 diesel with 1480 horsepower, only slight modifications were needed to make the existing model T10 meet new emission standards. With 5000 each motor in series worldwide and a reputation for dependability, EMD reassured that shop crews would prefer familiar technology.

Other than the prime mover, however, virtually every element of the SD70AC has been re-thought to create a 21st century locomotive. Ergonomics were a prime consideration. The engine's angular nose offers the crew a better visibility than most other locomotives, and the rail is comfortable for engineers of almost any size. Digital screens provide a range of information on what is happening both inside the locomotive and out on the track. The cab easily accommodates a crew of three — an important factor in a modern world without railroads. And there is, of course, a copilot for the engineer.

The SD70AC also offers, in EMD's words, "outstanding improvements in maintainability." All electrical wires are on the right side of the locomotive and all piping is on the left, with most pipes and wires routed under the frame so they can be accessed to a main standing board at the bottom of the engine room. And the time between service intervals has been doubled, from every three months to every six months.

After a year of testing on the road and at the Association of American Railroads' test track in Pueblo, CO, the first SD70AC's (4) (models for "reference") were delivered to CSX Transportation in 2004. Today they are tested by trains every day American Class 1 railroad. At the exact same time, mainline American railroads generally maintain dual fleets of locomotives. AC power is used for heavy coal hauling and isolated low-voltage traffic because AC traction motors offer higher starting tractive effort with the same horsepower. Less expensive, additional DC power is used for more mundane duties. But with the SD70AC, Electro-Motive hopes it may have the 21st Century successor to its 1943 Diesel — a locomotive that can be nearly as tight as its railroad.

New for 2005, MTH introduces the SD70AC as our first HO scale diesel, offered in a large variety of attractive paint schemes including the 1:1 engine Union Pacific heritage fleet. Each one-of-a-kind heritage fleet locomotive honors a "heritage flag" railroad that is now part of the Union Pacific system. Our highly detailed model includes a broader range of features than you'll find on any other HO scale diesel, including opening working ditch lights, smooth performance from a three-scale-motor-carrier-travel-to-full-brake, "feature control" for steady speeds regardless of curves, switches and grades, built-in decoders for DCC and the MTH Digital Command System (DCS), and a full range of sounds recorded from a genuine Union Pacific SD70AC. If you're looking for modern motive power that's incredibly detailed (our modeling allows us to create up to eight different SD70AC variations), smooth running, and a great deal of fun to operate, it doesn't get any better than this.

Did you know?

IntelliTrain, an option on the SD70AC, uses cellular and GPS technology to allow a railroad's maintenance department to monitor operating conditions and problems as they occur out on the road — making diagnosis and repair considerably easier.

Product Features

- Incredibly Detailed ATO Decoder
- Authentic Paint Schemes & Cab Numbers
- Detailed Track Sides, Pits and Fuel Tank
- Die-Cast Motor (Optional)
- Detachable Scale Snow Plow
- (2) Cab Figures
- Directly Controlled Headlights
- HO-26 Metal Wheels Mounted On Metal Axles
- Powerful 5-Pole Precision Frequency Equipped Motor
- Locomotive Speed Control in Scale MPH Measurement
- Lighted Cab Interior
- Blunkard Front-End Beams
- Lighted Motor Lights
- Operating Ditch Light
- (2) Scale-Ready Compatible Remotely Controlled Probe Couplers
- On-board DCC Receiver
- Operates On Code 70, 83, & 100 Rail Curves

Proto-Sound 3.0 equipped locomotives can be controlled in a command mode with any DCC compliant command control system, while the user will have access to all of the incredible features of Proto-Sound 3.0, independent control over the locomotive is possible. This means you can continue to use your existing DCC controller to independently control your other DCC equipped locomotives in addition to your Proto-Sound 3.0 locomotives on the same track at the same time.

When using a DCC controller, the following Proto-Sound 3.0 locomotive features are accessible:

- o F0 Headlight
- o F1 Bell
- o F2 Whistle/Horn
- o F3 Chime/Whistle Chime
- o F4 Rear Coupler
- o F5 Front Coupler
- o F6 Engine Sounds On/Off
- o F7 Sound Volume
- o F8 Ditch Lights Auto/Off
- o F9 Forward Signal
- o F10 Reverse Signal
- o F11 Double Crossing Signal
- o F12 Cab Light On/Off
- o F13 Behavioral Object 1
- o F14 Extended Shut Down
- o F15 Wn Up
- o F16 Wn Down
- o F17 Coupler Blank Sound
- o F18 Coupler Close
- o F19 Dec-Shut Coupler
- o F20 Feature Freeze
- o F21 Mile Sequence 1
- o F22 Mile Sequence 2
- o F23 Mile Sequence 3
- o F24 Ditch Lights Auto/Off
- o F25 Inboard Auto/Off
- o F26 Cab Chatter Auto/Off
- o F27 Cloudy-Clear Auto/Off
- o F28 Coupler Slack Sound
- o Proto-Sound 3.0 with the Digital Command System Featuring Freight Yard Proto-Effects
- o Unit Movement: 18 (11" x 111" x 2.311")
- o Operates On 12" Radius Curves

Click Here to View the Exploded View Drawing and Parts List

See Downloads



You will need the Adobe Acrobat reader to view our electronic documents. [Click Here to Download](#)

Service & Warranty Information

How to Get Service Under the Terms of the Limited One-Year Warranty

When you suspect an item is defective, please check the operator's manual for standard operation and trouble-shooting techniques that may correct the problem. Additional information may be found on the M.T.H. Website. Should you still require service, follow the instructions below to obtain warranty service.

First, e-mail, write, call or fax a M.T.H. Authorized Service Center (ASC) in your area to obtain Repair Authorization. You can find the list of ASCs on the M.T.H. Website, www.mth-railking.com. Authorized Service Centers are required to make warranty repairs on items sold *only* from that store; all other repairs may-- or may not be done at the store's own discretion. If you did not purchase the item directly from the ASC, you will need to select a National Authorized Service Center (NASC). These centers are compensated by M.T.H. to perform warranty service for any customer whose repair qualifies for warranty service. A list of NASC retailers can be located on the M.T.H. Website or by calling 410-381-2580. Should the warranty no longer apply, you may choose either an ASC or NASC retailer to service your M.T.H. Product. A reasonable service fee will be charged.

CAUTION: Make sure the product is packed in its original factory packaging including its foam and plastic wrapping material to prevent damage to the merchandise. There is no need to return the entire set if only one of the components is in need of repair *unless otherwise instructed by the Service Center*. **The shipment must be prepaid and we recommend that it be insured. A cover letter including your name, address, daytime phone number, e-mail address (if available), Return Authorization number (if required by the service center, a copy of your sales receipt and a full description of the problem must be included to facilitate the repairs. Please include the description regardless of whether you discussed the problem with a service technician when contacting the Service Center for your Return Authorization.**

Please make sure you have followed the instructions carefully before returning any merchandise for service. Authorized M.T.H. Service Centers are independently owned and operated and are not agents or representatives of M.T.H. Electric Trains. M.T.H. assumes no responsibility, financial or otherwise, for material left in their possession, or work done, by privately owned M.T.H. Authorized Service Centers.

If you need assistance at any time email MTH Service at service@mth-railking.com, or call 410 381-2580.

Limited One-Year Warranty

All M.T.H. products purchased from an Authorized M.T.H. Retailer are covered by this warranty. See our Website www.mthtrains.com to identify an M.T.H. Retailer near you.

M.T.H. products are warrantied for one year from the date of purchase against defects in material or workmanship, excluding wear items such as light bulbs, pick-up rollers, batteries, smoke unit wicks, and traction tires. We will repair, replace, or credit (at our option) the defective part without charge for the parts or labor, if the item is returned to an M.T.H. Authorized Service Center (ASC) or M.T.H. National Authorized Service Center (NASC) within one year of the original date of purchase. This warranty does not cover damages caused by improper care, handling, or use. Transportation costs incurred by the customer are not covered under this warranty.

Items sent for repair must be accompanied by a return authorization number, a description of the problem, and **a copy of the original sales receipt from an Authorized M.T.H. Train Merchant**, which gives the date of purchase. If you are sending this product to an Authorized Service Center, contact that Center for their return authorization.

This warranty gives you specific legal rights, and you may have other rights that vary from state to state. Specific questions regarding the warranty may be forwarded to M.T.H. Directly.

Service Department:
M.T.H. Electric Trains
7020 Columbia Gateway Drive
Columbia MD 21046-1532