



UNION PACIFIC BIG BOY ARTICULATED STEAM ENGINE OPERATING INSTRUCTIONS For 2 & 3-Rail Models



Thank you for purchasing the MTH Electric Trains Union Pacific Big Boy Die-Cast 4-8-8-4 steam engine. This 1/4" scale reproduction of the famous Union Pacific locomotive measures over 35 inches in length and weighs over 19 pounds. Despite its scale size it still operates on standard O-72 3-rail track with any compatible standard AC transformer, see page 24, and is completely compatible with most 3-rail locomotives, rolling stock and accessories. If you purchased the 2-rail version, the engine should negotiate 72 inch radius track and is compatible with any DC power source.

The 3-rail locomotive and tender are equipped with several deluxe features that are simple and fun to operate. Each feature is described among the following pages which should be read before the engine is operated. For those of you who can't wait to get started, the Quick Start Operating Instructions found on Page 3 should be read so that you understand the basics of the operating system. Those features marked for 2 and 3-rail are found in both versions. Features not marked as such are only available in the 3-rail version.

Table Of Contents

QUICK START - BASIC OPERATION(2 and 3-Rail Models)	3
SMOKE UNIT OPERATION	4
PROTOSOUNDS™ OPERATING INSTRUCTIONS	5
DCRU™ REVERSE UNIT OPERATION(All 3-Rail Models)	6
WHISTLE OPERATION	7
BELL OPERATION	7
ENHANCED NEUTRAL STEAM SOUNDS	7
SQUEAKING BRAKE SOUNDS	8
ACTIVATING AND TRIGGERING THE SQUEAKING BRAKE SOUNDS	8
TIPS ON USING THE SQUEAKING BRAKE FEATURE	9
FREIGHT YARD SOUND EFFECTS (FYS)	9
ACTIVATING AND TRIGGERING FREIGHT YARD SOUNDS	10
TIPS ON USING THE FYS FEATURES	12
PROTO-COUPLER OPERATION	13
SELF-RECHARGING BATTERY BACKUP SYSTEM	13
REPLACING THE PROTOSOUND™ BATTERY	14
PROTOSOUND™ VOLUME ADJUSTMENT	14
USING “RESET” TO PROGRAM PROTOSOUNDS™	15
ENTERING RESET OPTIONS	15
SETTING THE ENGINE CHUFFING VOLUME	15
PROGRAMMING FOR A SEPARATE BELL BUTTON CONTROLLER	16
PROGRAMMING FOR WHISTLE IN NEUTRAL OPERATION	16
PROGRAMMING FOR PROTOCOUPLER OPERATION	17
PROGRAMMING FOR SQUEAKING BRAKES AND FYS OPERATION	17
ACTIVATING REMOTE LOCK-OUT CONTROL	18
RESETTING ALL PROTOSOUND OPTIONS TO FACTORY DEFAULTS	18
REVERSE UNIT LOCK-OUT OPERATION	19
LOCKING THE ENGINE INTO FORWARD OR REVERSE	19
UNLOCKING THE ENGINE	19
LOCKING THE ENGINE INTO NEUTRAL	19
OIL & LUBRICATION INSTRUCTIONS	20
TRACTION TIRE REPLACEMENT INSTRUCTIONS	21
LIGHT BULB & SMOKE UNIT REMOVAL & REPLACEMENT	21
TROUBLE SHOOTING PROTOSOUND™ PROBLEMS	22
TRANSFORMER COMPATIBILITY AND WIRING CHART	25
PROTOSOUND RESET FEATURE CHART	26
SERVICE AND WARRANTY INFORMATION	27
HOW TO GET SERVICE	27
LIMITED ONE YEAR WARRANTY	27

QUICK START - BASIC OPERATION

The MTH Union Pacific Big Boy contains state-of-the-art electronics with several built-in automatic features for incredibly realistic operation. Despite these advanced features, the Big Boy is easy to operate with any compatible standard AC transformer. (See the compatibility chart on page 24) The 2-rail model will operate with any DC power supply. All models are equipped with an operating smoke system that **must be primed with smoke fluid before operating**. Adding 15 - 20 drops of fluid through the smoke stack should be sufficient. **If you choose not to prime the unit with fluid, turn the smoke unit switch located under the locomotive trailing truck to the OFF position (see Figure 2 on page 4).** This will prevent any damage from occurring to the smoke unit when running the engine without a primed smoke unit. See the section on page 4 on Smoke Unit operation for more information.

All 3-rail models are controlled by a DCRU™ reverse unit as part of the MTH ProtoSound™ package. The reverse unit operates in the same manner that all reverse units function by using forward, neutral and reverse states that are entered by turning the transformer throttle on and off or by pressing the transformer direction switch (if so equipped). The 2-rail models' direction is controlled through the polarity of the DC power source and operate the same as all 2-rail DC engines. 2-Rail engines are NOT equipped with ProtoSound.

The reverse unit is designed to ignore dirty track, dead spots on switches or minor short circuits without disrupting engine operation, even at slow, prototypical speeds. Before the engine can be operated, however, the reverse unit plug that extends out of the tender must be inserted into the receptacle at the back of the boiler cab as seen in Figure 1. Once the plug is inserted, the throttle on the transformer can be advanced. You will see that only the engine's lights will come on and two dings from the sound system will chime as the steam compressor pumps begin. This is known as the RESET state and is explained in more detail on Page 6. The DCRU will not power the motor until the throttle is turned OFF and then ON again. At this point, the engine will now function like any other electronic or mechanical E-Unit. The steam engine chuffing will begin as the engine moves and the whistle can be blown just as any normal whistle is activated by pressing the whistle button on your transformer. See the sections later in this guide beginning on Page 7 for more information on activating the whistle and bell sounds.

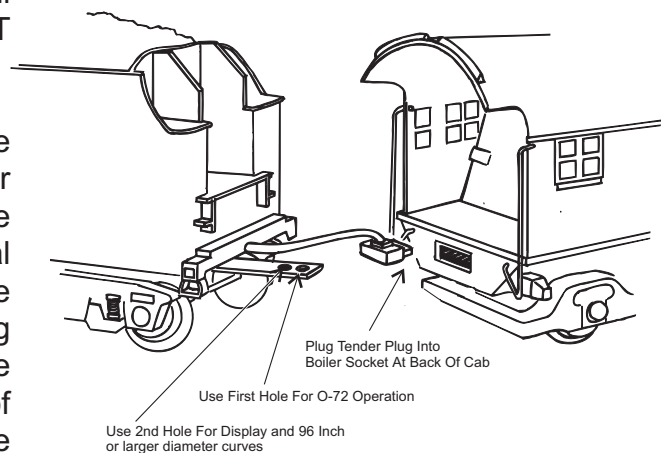

Figure 1: Plugging In The Tender Harness

Finally, we recommend lubricating your engine before operating it to prevent any squeaking. See the lubrication directions on Page 20.

SMOKE UNIT OPERATION

The Big Boy contains a self-powered smoke units that output a steady stream of smoke through the smoke stack. The ON/OFF switch located next to the locomotive trailing truck must be in the ON position in order for the smoke unit to function. See Fig. 2.

The smoke unit is essentially a small heating element and wick which soaks up and then “cooks” a mineral oil-based fluid that omits a harmless smoke. The smoke is then forced out of the stack via a small electric fan which runs at a constant speed. However, the smoke intensity can be varied by increasing the transformer voltage setting. The higher the setting, the more intense the smoke output.

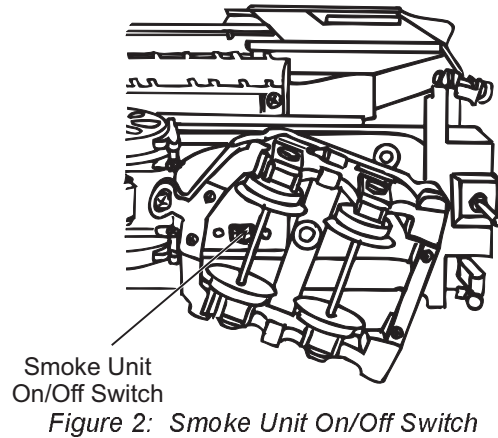

For best results, we recommend that you add 15 - 20 drops of Seuthe, LGB or LVTS fluid **before you run the engine. If you don't choose to add the fluid, then the smoke unit switch should be turned off.** Failure to either add the fluid or turn the switch off could lead to damage to the smoke unit heating element and or wicking. Add the fluid through the smoke stack hole as indicated in Figure 3.

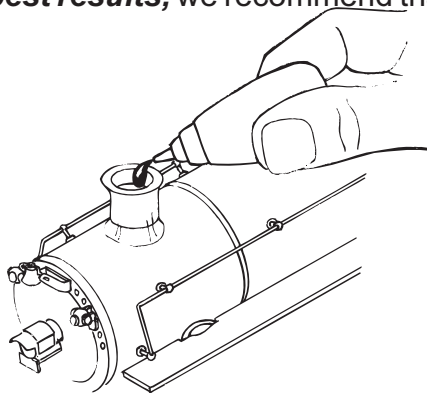

Figure 3: Adding Smoke Fluid

After adding the fluid, gently blow into the stack to eliminate any air bubbles. Do not overfill the unit as overfilling can cause the fluid to leak out and coat the interior engine components. When the smoke output begins to diminish or becomes light while running the engine, an

additional 10-15 drops of smoke fluid should be added or the smoke unit switch should be turned off. In addition, by letting the engine sit for five minutes after filling, the wick can better soak up the fluid resulting in improved smoke output.

When storing the engine for long periods of time, you may want to add at least 15 drops of fluid to keep the wick soaked with fluid and prevent it from drying out. After removing the engine from storage, it is advisable to add another 25 drops of fluid, letting the wick soak up the fluid for 15 minutes prior to operation.

SMOKE UNIT MAINTENANCE

CAUTION: Operating the engine without smoke fluid and with the smoke unit switch in the ON position can damage your smoke unit wick, causing the wick to become hard, blackened and unabsorbant around the heating element. When this occurs, it may be

difficult for the wick to soak up the smoke fluid resulting in poor or no smoke output. If that occurs, we recommend that you inspect and/or replace the wick taking care to not run the engine without fluid in the future. You can inspect the wick to see if it needs replacement by removing the smoke unit inspection cover as seen in Fig. 4. After removing the screws lift the inspection plate away and inspect the wick. If the wick is darkly discolored and hard, it should be replaced.

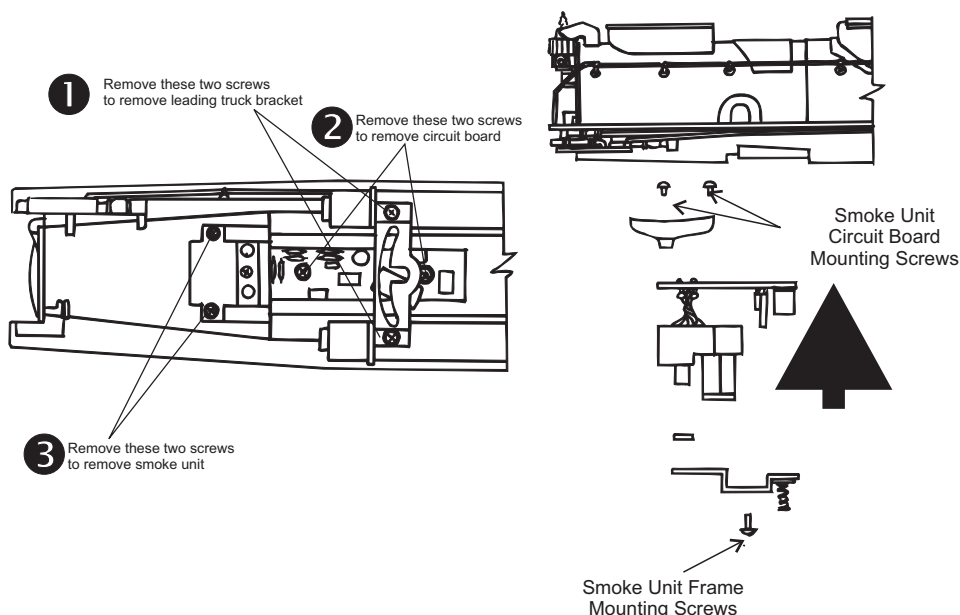

Figure 4: Removing The Smoke Unit

NOTE: Replacement bottles of smoke fluid, such as LGB or LVTS, are available at most hobby shops. Replacement smoke unit wicks can be purchased directly from MTH Electric Trains.

PROTOSOUNDS™ OPERATING INSTRUCTIONS

The MTH ProtoSound™ digital sound and train control system provides the operator with unprecedented realistic operation on your model railroad. In addition to actual articulated steam CD-equivalent, 16-bit digital sounds, you get the following features, each of which is further described on the following pages. Every feature is easily and remotely controlled from any compatible AC transformer equipped with a whistle button. See the chart on page 24 for a list of compatible transformers.

Built-In DCRU Reverse Unit
 Authentic Hudson Bell & Whistle
 Enhanced Neutral Steam Sounds
 Squeaking Brake Sounds
 Freight Yard Sounds
 Remote Controlled ProtoCoupler

Self-Recharging Battery Back-Up
 Remotely Controlled Reverse Unit
 Remotely Activated Lock-Out
 Remotely Adjustable Steam Volume
 Upgradeable Microprocessor Options

DCRU REVERSE UNIT OPERATION

As mentioned in the Basic Operating section, the engine is controlled by a DCRU reverse unit that contains the standard forward-neutral-reverse states found on most reverse units. However, as described earlier, when power is first applied to the track, the reverse unit begins in RESET or what seems like a neutral state. Power must be interrupted again to get the locomotive to enter the forward state. It is this first RESET state that gives ProtoSound™ its unique, remote controlled functions. The system will enter RESET whenever power to the track is off for three or more seconds. NEUTRAL will be referred to as the state between Forward and Reverse.

ProtoSounds™ is equipped with a microprocessor, that, depending on the amount of memory it is allotted, allows the user to utilize several remotely activated functions. In the simplest terms, ProtoSounds™ has its own "Computer" controlling these functions. In fact, the power of this microprocessor is the same as that of a 286 desktop computer! In order to access many of these remotely controlled functions, the user must be in the RESET state to do so. RESET is entered anytime power to the locomotive has been off for more than 3-5 seconds. When the engine first enters RESET, the microprocessor initiates a system check to determine if the system, transformer and engine are operating correctly. This takes approximately 2.2 seconds during which you will hear the engine's air compressor start up. In order for ProtoSounds to properly initiate the system check, do not advance the transformer throttle past 10 volts when you first enter RESET, then wait for the steam compressor pumps to begin before slowly turning the throttle to the off position and then back on again to enter the Forward phase. If you enter RESET at too high a voltage, interrupt the power too soon, or move the throttle too quickly to the off position, the system may reenter RESET (signaled by two dings of the bell). Should this happen, wait longer before interrupting the power to enter the Forward phase.

ProtoSounds™ comes with several programmable functions including; remote steam chuffing volume adjustment, separate bell button operation, remotely activated Proto-Coupler, Whistle in neutral operation, enhanced neutral steam sounds, squealing brakes and passenger station announcement sounds. Each of these features are described in more detail later and all can be remotely activated from any compatible standard AC transformer with a whistle button (See the chart on page 24). (Additional features will be available at additional prices from MTH ProtoSound Electronics) You will notice that when in RESET, your engine will not respond to the whistle button with a whistle blast or continuous bell ringing. In fact, when in RESET and the whistle button is depressed, only one single bell chime will be heard each time the button is pressed. This is because the computer is awaiting programming instructions from one of the many RESET settings. If you don't wish to configure ProtoSounds using any of the programmable features, simply leave RESET at this time by interrupting the power to put the engine in forward. After you leave RESET, your engine will operate normally in all the direction states of forward, neutral and reverse. Remember, though, once power is turned off for more than 3 seconds, the next time power is applied to the track, your engine will be back in RESET.

WHISTLE OPERATION

Your Big Boy engine is equipped with a digital recording of an articulated steam engine whistle. The whistle sound can be activated anytime the engine is in forward or reverse by pressing the whistle button on your transformer. The whistle will continue to blow as long as the whistle button is depressed. The whistle will not function in Neutral or RESET. It can, however, be configured to operate in Neutral by accessing and programming a RESET option. See page 16 for information on whistle programming in the section entitled "Using RESET To Program ProtoSounds" section of this manual.

BELL OPERATION

Your Big Boy engine is equipped with a digital recording of an actual steam engine bell. The bell can be turned on or off when the engine is in Forward, Neutral or Reverse from either of two procedures; using a bell activation button, like the Lionel® Railsounds™ No. 5906 Bell Button, or by pressing your transformer whistle button when your engine is in neutral. The bell will never function continuously in RESET. Once the bell is turned on, it will continue to ring when the engine is cycled into forward, neutral or reverse until you turn the bell off by pressing the bell button or by re-entering NEUTRAL and pressing the whistle button. In fact, because of ProtoSounds™ state-of-the-art design, the microprocessor remembers its last command. Therefore, unless you turn the bell off before you quit running your trains, the next time you run the engine, the bell will come on. No matter whether you come back an hour later or a year later, the bell will begin chiming once the engine enters one of the three directional states.

TO TURN THE BELL ON OR OFF WITH A BELL BUTTON

To turn the bell on, turn on power to the track and cycle the engine into Forward, Neutral or Reverse. Press the bell button to activate the bell sounds. To turn off the bell sounds, press the bell button a second time. If the bell button doesn't activate the bell, check that it is correctly wired up to the track and transformer as indicated in Figure 8 on page 16.

TO TURN THE BELL ON OR OFF WITH A WHISTLE BUTTON

Turn on track power and cycle the engine into the Neutral state. Turn the throttle to 8 volts or less (any higher voltage will arm the ProtoCoupler) and press the whistle button. The bell should begin chiming. To turn the bell off, press the whistle button again. If you want to keep the bell on while running the engine, simply interrupt the power with the transformer throttle or the transformer directional switch and enter forward or reverse. To turn the bell off, reenter Neutral, setting the transformer voltage at eight volts or less and press the whistle button. The bell should stop ringing. Remember if you don't have a separate bell button controller, you must be in Neutral to turn the bell on or off.

ENHANCED NEUTRAL STEAM SOUNDS

The enhanced Neutral Sounds can be automatically heard whenever the engine is in neutral. The sounds, which include Steam Pop-Off, Steam Blow-Down and Steam Injector sounds occur every 2 to 30 seconds. Each of the three sequences will play at random times. This helps to eliminate repetitive and boring sound sequences. While the sounds are selected to play randomly by the microprocessor, there is no guarantee that you won't hear the same message repeated twice or more times.

SQUEAKING BRAKE SOUNDS

ProtoSounds is now equipped with operator controlled squeaking brake sounds. Once activated, this easy to use feature plays the sound of squeaking brakes whenever the transformer throttle is reduced from high voltage to low voltage simulating the application of the brakes as you enter curves or slow down for crossings and passenger stations. The sound itself is a stored record on the ProtoSounds software chip and will always play the same brake sound for the same 3 second length each time you reduce the voltage from high to low.

ACTIVATING AND TRIGGERING THE SQUEAKING BRAKE SOUNDS

Before the brake squeaking can be heard, ProtoSounds must be activated for the brake sound feature. The brake sound feature can be activated in two ways.

Option 1: If you are using a separate bell button controller to ring your bell (like the Lionel Railsounds No. 5906 bell activation button) you can activate the squealing brake feature by pressing and holding the bell button for three seconds or longer (it doesn't matter if you are in forward, neutral or reverse). You will hear the bell chiming turn on and if you listen carefully you should hear an air release sound after three seconds have passed at which time you can release the bell button. (*Note: because the air release sound is hard to hear, we recommend that you count out a full three seconds before releasing the bell button.*) The bell will continue to chime, so if you want to turn off the bell ringing, simply press and release the bell button a second time. If you were in neutral when you triggered the brake feature, interrupt the transformer throttle to enter either forward or reverse to allow the engine to begin running. (*Note: the brake sound will only be activated in the first direction state you enter after triggering the feature from the neutral position. You cannot interrupt the power twice to enter another direction state and still have the brake feature active.*) Once your engine begins running, you can activate the brake sounds by reducing the transformer voltage from a high setting to a low setting.

Option 2 If you do not have a separate bell button on your layout, you can still activate the brake sound feature with your transformer whistle button. To activate the brake feature turn on the transformer throttle and get your engine into the neutral position (not RESET). Once in neutral, set the transformer throttle at 8 volts or less and press and hold the whistle button for at least three seconds. You will hear the bell chiming turn on and if you listen carefully you should hear an air release sound after three seconds have passed at which time you can release the whistle button. (*Note: because the air release sound is hard to hear, we recommend that you count out a full three seconds before releasing the whistle button.*) The bell will continue to chime, so if you want to turn off the bell ringing, simply press and release the bell button a second time. Interrupt the transformer throttle to enter either forward or reverse to allow the engine to begin running. (*Note: the brake sound will only be activated in the first direction state you enter after triggering the feature from the neutral position. You cannot interrupt the power twice to enter another direction state and still have the brake feature active.*) Once your engine begins running, you can activate the brake sounds by reducing the transformer voltage from a high setting to a low setting.

Note: Once the brake feature is activated and the engine is running, it is possible that the brake sounds may not occur if the transformer throttle setting is not set high enough before throttling down. We recommend that after activating the brake feature, you run the engine at no less than 14 volts before throttling down to approximately 8 volts or less to ensure that the brake sounds occur.

Note: After activating the brake feature, whenever you stop the engine by either turning the transformer throttle off or by entering neutral, the brake feature becomes disabled and must be reactivated using either of the two methods above.

Note: If the brake feature is activated using method number 1 from either forward or reverse and you interrupt the throttle to enter neutral and leave the throttle on, you may activate another ProtoSound feature in this engine; Passenger Station Announcement. See the section later in this manual on Passenger Station Announcement.

TIPS ON USING THE SQUEAKING BRAKE FEATURE

Because the squeaking brake feature always plays for approximately 3 seconds, it is possible that the brake sounds will play longer or shorter than what visually seems prototypical. You will find that by practicing with the brake feature, you can quickly determine how quickly to throttle down and what speeds and voltage settings give you the most prototypical braking effect.

Typical users will find the feature to be a very realistic way to simulate the sound of an engine slowing down for curves, crossings or coming to a stop at a station, side track or switch yard. As mentioned above, you will find that initially your engine may continue to play the brake sounds once your engine comes to a stop or that the sounds stop prematurely before the engine comes to a complete halt. For example, if you simply run the engine and turn the throttle off quickly, the brake sounds will likely continue playing even though the engine has come to a complete stop. This annoying effect can be eliminated by simply practicing with the brake feature. In no time, you will quickly learn how to “feather” the throttle to keep the engine moving while the brake sounds play and then turning the throttle off just as the sounds stop. Remember that once you stop the engine, you should turn the throttle to the off position if you don’t want to activate the Freight Yard Sounds feature described later in this manual.

FREIGHT YARD SOUNDS (FYS)

ProtoSounds™ comes equipped with operator controlled Freight Yard Sounds, hereby referred to as FYS. This easy to use feature plays digitally reproduced freight yard sounds whenever your engine stops on your layout and is parked in the Neutral position. No additional wires or modifications are needed on your layout to enjoy these amazing sound effects. The sounds themselves are randomly generated and randomly “shuffled” on the ProtoSounds™ software chip. This gives the system the ability to produce different sounds in a different order each time FYS is enabled. These different sounds are heard each time you cycle the transformer throttle from ON to OFF in the same manner that you would cycle

the throttle to enter the various states of Forward, Neutral and Reverse. The entire FYS sequence is designed to simulate the arrival, loading or unloading and departure of a freight train in a freight yard. Each sequence is described in more detail in the following sections.

ACTIVATING AND TRIGGERING FREIGHT YARD SOUNDS

Before FYS can be heard the feature must be activated first. Activation is accomplished by holding down the bell button for three or more seconds as described in the Activating and Triggering The Squeaking Brake Sounds section found earlier on page 8. Once the squeaking brake feature is activated, FYS will be played the next time the engine enters the neutral position. In order for FYS to begin, power must remain on once the engine enters the Neutral position. At this point ProtoSounds™ has taken over control of your engine and disabled the bell and whistle buttons from any further operator functions. In addition, ProtoSounds™ has reconfigured the way the DCRU Reverse Unit functions by disabling the reverse unit state during operation of the FYS feature. This forces the engine to leave your freight yard in the same direction it arrived in. The following operator controlled “events” control FYS’s actions and sounds.

Event 1 (Forward) While the locomotive is running in forward (or reverse) FYS is activated by the operator pushing and holding the bell button down for three or more seconds. The locomotive bell begins chiming and can be left on or turned off without disabling FYS.

Event 2 (Neutral Before Reverse) The operator now interrupts the transformer throttle to stop the engine and put it into Neutral. If the throttle setting was at 14 volts or higher, ProtoSounds™ will play the sound of squeaking brake sounds as the engine comes to a halt.

A. Upon stopping of the engine, the operator must immediately turn the throttle back on to keep the engine in the Neutral position. If the bell was not turned off after activating FYS, it now turns off automatically.

Note: *Failure to turn the throttle back on within 3 seconds of leaving the Forward phase will disable FYS and shutdown ProtoSounds™. The next time you turn power back on your engine will be in the RESET position. See page 6 for more information on RESET.*

B. After entering Neutral, ProtoSounds™ will immediately play an air release sound followed approximately 2 seconds later by a man whistling and a freight car door sliding open. Immediately following the man’s whistle, the sound of freight car doors can be heard opening, followed by the sounds of freight loading and unloading. At this point various freight yard sounds can be heard including the loading/unloading operation, engine sounds, yardman “slang”, and additional freight car door sounds.

Event 3: (Reverse) The operator now interrupts the transformer throttle again to enter the next reverse unit phase; reverse. In an effort to enhance realism, FYS has disabled the reverse phase so that it doesn't power the motors causing the engine to move backward. Upon entering reverse, FYS confirms to the operator that it has entered the reverse phase by immediately playing a highlight sound best described as a rumbling sound. You may have to go through the entire FYS sequence several times before you can clearly identify this sound. After the rumbling highlight is played, the freight yard sounds heard in Event 2 continue to play randomly.

Event 4: (Neutral Before Forward) The operator now interrupts the transformer throttle again to enter the next reverse unit phase, neutral before forward. FYS confirms to the operator that it has entered the neutral before forward phase by emitting two quick air release sounds. This is followed approximately two seconds later by a man whistling and continued freight yard loading and unloading sounds.

Event 5: (Forward) The operator now interrupts the transformer throttle again to enter the next reverse unit phase; Forward. FYS confirms to the operator that it has entered the Forward phase by playing the sound of the freight car door closing. Within 2 seconds of the door closing, the locomotive bell begins chiming. After approximately 8 chimes of the bell, the engine begins moving in the forward phase with the bell continuing to ring another 8 chimes before automatically turning off. Once the bell turns off, the operator regains control of the transformer whistle and bell buttons and can ring the bell or blow the whistle as usual.

Note: *When entering the Forward phase of FYS, it is important to set the transformer throttle at a high enough setting that will allow the engine to begin moving once FYS automatically activates the motors. Otherwise the engine will just sit still until you increase the transformer throttle setting on the transformer. However, don't set the throttle setting too high or the engine will go racing away faster than you might expect.*

TIPS ON USING FYS FEATURES

FYS is a unique feature of ProtoSounds™ that is completely controlled by the operator. You decide how, when or if you want to utilize the feature. By reviewing the following tips, you should find solutions or suggestions to the various operating scenarios you might encounter when using FYS.

Tip #1: You can escape the FYS sequence by interrupting the transformer throttle before the man whistles in Event 2 (neutral before reverse).

Tip #2: You can terminate FYS at anytime by turning the transformer throttle Off for 15 seconds.

Tip #3: You do not have to be in the Forward phase to utilize FYS. For example, if you activate the FYS feature while in Reverse and interrupt the throttle to enter Neutral, you will be entering Neutral Before Forward rather than Neutral Before Reverse as defined in Event 2 above. Consequently, the Forward phase will be rendered inactive by ProtoSounds™ instead of the Reverse phase as explained in Event 3. This will allow your train to leave the yard in the same reverse direction that it arrived in.

Tip #4: You can utilize FYS even if you are double-heading with another engine regardless of whether the second engine is equipped with an FYS programmed ProtoSound™ module. If the second engine isn't equipped with FYS, the only thing to remember is that you not turn up the transformer throttle very high when entering the Reverse phase found in Event 3. If the throttle is set too high, then the second locomotive will begin vibrating on the track as its motors will be turning in the reverse state since they cannot be disabled automatically like FYS equipped engines. If your second engine is equipped with FYS, you may want to disable it when used in double-headed operations. To disable FYS, see the section on programming for squeaking brakes and FYS operation on page 15 of this manual.

Tip #5: It is not necessary for the squeaking brake sounds to be heard to play the FYS sounds. for example, the brake sounds won't be heard if the high voltage setting is below 13 volts when the power is interrupted to enter the Neutral state.

Tip #6: You can leave any of the event states at any time after entering the state by simply interrupting the transformer throttle. Any sound effects programmed to play in that event will simply not occur. The only exception is Event 2 and Event 5. In Event 2, interrupting the throttle has no effect on FYS until after the man whistles and the freight car doors have opened. In Event 5, you cannot interrupt FYS until after the engine begins to move. Interrupting the throttle before the engine begins to move has no affect on the locomotive's operation.

PROTO-COUPLER OPERATION

Your Big Boy locomotive has a coil-wound ProtoCoupler™ mounted on the tender for remote controlled coupler operation. Because it is controlled through ProtoSound's microprocessor, it doesn't require an uncoupling track section or modification to your layout to function. The ProtoCoupler can be activated with any compatible standard AC transformer equipped with a whistle button. For a list of compatible transformers, see the chart on page 24. The three simple steps below are required to operate the coupler.

- A. Put your engine in NEUTRAL and turn the throttle all the way up.
- B. Press the whistle button on your transformer to "Arm" the coupler.
- C. After arming the coupler, press the whistle button again to open the coupler.

When the knuckle fires open you will hear the buzzing of the coil energizing and the sound of the air lines coming apart. It can best be described as a CHA-CHUSHHH sound. Once the coupler is armed it can be fired in Forward, Neutral or Reverse. However, you may find that the coupler doesn't open when firing the coupler at high speeds or high voltage settings. Reduce the voltage setting on your transformer if this occurs and run your engine at a slower speed before firing the coupler. If the coupler continues to open erratically, try lubricating the coupler knuckle with light household oil as indicated in Figure 5.

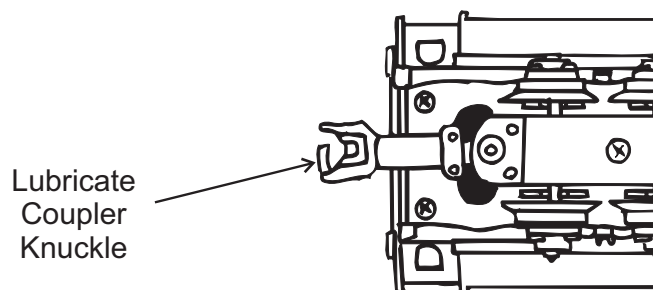

Figure 5: Lubricating The Coupler Knuckle

SELF-RECHARGING BATTERY BACKUP SYSTEM

ProtoSounds™ state-of-the-art design includes a self-recharging battery backup system for improved performance at any speed. There are no switches to turn on or off to enjoy the benefits of the automatic battery backup system as this feature is automatically activated whenever track power is turned on. The battery ensures that power to the sound system will not be interrupted during directional changes, setting RESET options, or when traveling over dirty track and switches. You will know the backup system is operating as sound will no longer abruptly shut off whenever a momentary interruption in track power occurs.

ProtoSounds contains a warning alarm if the battery backup system fails to automatically turn off when power to the track is turned off. You will hear a repeating whistle blast indicating that the backup system hasn't turned off. Should this occur, you will need to unplug the battery from the ProtoSound module to prevent the battery from being run down.

REPLACING THE PROTOSOUND BATTERY

The battery, located in the engine's tender (see the tender disassembly instructions on page 20), is a rechargeable NiCad type which is continually charged from the track when power is applied. NiCad batteries are a dry battery and should not leak or cause any damage to your locomotive and will last up to five years or longer.

If you notice that the sounds seem distorted or garbled at low voltages or become silent when power from the transformer is shut off, the battery may be going bad. Before replacing the battery, you should put the engine in NEUTRAL and leave the transformer throttle at about 12 volts for fifteen minutes. This should temporarily recharge the battery. If the garbled or distorted sounds are reduced, then your battery charge has worn down. You can give your battery a full charge by leaving the engine ON in NEUTRAL for 16 to 18 hours. (Make sure the smoke unit switch is in the OFF position to prevent harm to the smoke unit)

If you need to replace the ProtoSound™ battery, it is a special NiCad 7-cell, 8.4v battery - NOT the 6-cell, 7.2v battery found in most convenience stores. The 6-cell NiCad is NOT recommended for use with ProtoSound™ applications. Replacement ProtoSound™ batteries are available from MTH ProtoSound Electronics at 9693-A Gerwig Lane, Columbia, MD 21046. A standard 9v alkaline battery can be substituted as a temporary fix, but since alkaline batteries can't take a charge, it will eventually wear down. Regardless, it should give you a week to a couple of months use while you wait for your replacement ProtoSound™ battery to arrive.

PROTOSOUND™ VOLUME ADJUSTMENT

Your ProtoSound system has two types of volume adjustment. A manual turn knob on the bottom of the tender chassis (See Fig. 6) allows you to control all the sounds in the system and a remote control "RESET" option allows you to control the volume level of the steam engine sounds remotely from the transformer. Turning the volume adjustment knob clockwise will increase the volume and counterclockwise will lower the volume of all sounds; bell, whistle, steam chugging sounds, enhanced neutral sounds and others. For instructions on operating the RESET volume adjustment option, see the section entitled "Programming ProtoSound Reset Options" on the following pages.

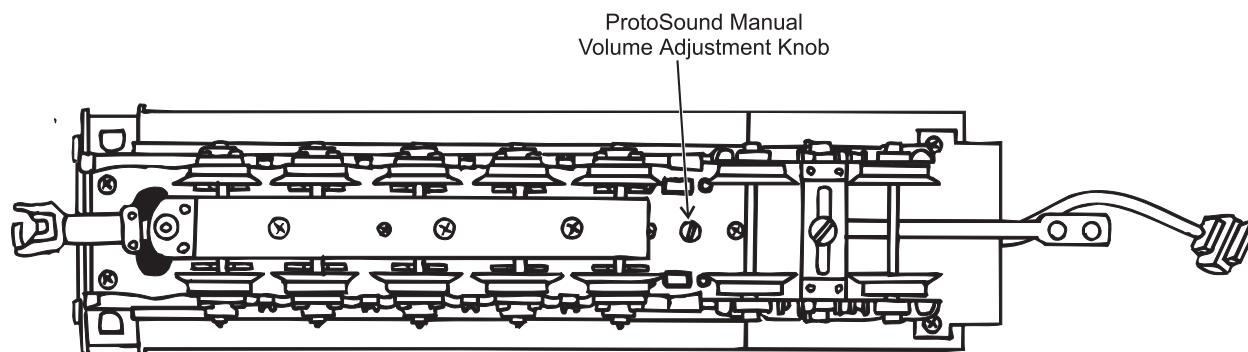

Figure 6: Adjusting The ProtoSound Volume

USING “RESET” TO PROGRAM PROTOSOUNDS™

As mentioned earlier, there are several programmable options in each ProtoSound-equipped engine that can be remotely set from any compatible standard transformer equipped with a whistle button. For a list of compatible transformers, see the chart on page 24. This hands-off approach gives you unprecedented control of your railroad empire's motive power never seen before in model railroading. Each programmable feature can be accessed whenever your engine is in the RESET state as described in the section entitled “DCRU Reverse Unit Operation” found earlier on page 6. By following the instructions below you will find the programming easy and straight forward.

ENTERING RESET OPTIONS

While ProtoSound™ is equipped with only a few programmable features, additional memory chips can be obtained to “Upgrade” the system in the future. Programmable features are accessed in the RESET state by moving the transformer throttle up and down between full voltage and low voltage (6 to 8 volts) without shutting the transformer off completely. Each time this is done you advance, one feature at a time, through the available options. An air-release sound is heard each time the throttle is advanced. In addition, there are special sounds to tell you what RESET position you are in.

For example, if you want to select Feature 2 (an optional memory feature that sets an ID number on your engine), you put the engine in RESET, and move the throttle up and down from full throttle to low two times. After the second advance, you will hear two “clinks” indicating that the computer is now in Feature 2. Advance the throttle again and you will hear three “clinks” for Feature 3. Advance it two more times and you will hear a “clank” indicating that you are now in Feature 5. Advance the throttle two more times and you will hear a “clank” and two “clinks” indicating Feature 7. ((5 throttle advancements = 1 clank) + (2 throttle advancements = 2 clinks). “Clank + “Clink” + “Clink” = Feature 7). You can advance the throttle as quickly as you like (though you may not hear the air-release sounds) and the computer will still remember the number of times the throttle is advanced by playing back the number of “Clinks” and “Clanks” to confirm the feature you've selected.

SETTING THE STEAM CHUFFING VOLUME

Of all the sounds that come with each ProtoSound-equipped steam locomotive, the one most often turned down is that of the steam chuffing volume because it is the one sound normally heard whenever the engine is running and is what usually can become tiresome to the ear over prolonged running sessions. The volume adjustment is controlled through RESET Feature 6.

To access the feature, turn on your transformer throttle to put the engine in RESET. Move the throttle up and down as described above 6 times. After you hear the “clank” and “clink” indicating that you are in Feature 6, press the whistle button to select the steam chuffing volume level you desire. Pushing the whistle button once will give you full steam chuffing volume, which is the factory setting. Pushing the whistle button a second time will give you 50% steam chuffing volume, pushing it a third time will give you 25% steam chuffing volume

and pushing it a fourth time will give you no steam chuffing sounds. The microprocessor will immediately play the sound level each time the whistle button is pushed so that you can decide if it is acceptable. You can recycle through the four choices by simply continuing to press the whistle button.

Once you have decided on the appropriate volume level, turn the transformer throttle off and on again or press the transformer direction switch to lock in your selection. The volume adjustment will remain set at the level you have chosen until you change it again. Regardless of the steam chuffing volume setting, the whistle, bell, steam compressor pumps and enhanced neutral sounds will function normally. In fact because only the steam chuffing volume is affected by selections in Feature 6, when you select 0 steam chuffing volume, you will still hear the compressor sounds when the engine is running. Don't confuse these sounds with the steam engine chuffing sounds.

PROGRAMMING FOR A SEPARATE BELL BUTTON CONTROLLER

To operate ProtoSounds with a separate bell button controller, you will need to wire up the controller to your transformer and track as per the instructions in Fig. 7. Once the bell button is wired, you can use the bell button to activate the bell in forward, neutral or reverse. If the bell doesn't operate and is wired up correctly, you will need to program the ProtoSound module to operate with a bell button. To do this, enter RESET and go to Feature 20. (See the section "Entering RESET Options" on page 15.) Once in Feature 20, press the whistle button and wait for the module to sound a bell ding(s). Continue pushing the whistle button until the module plays back one ding (signifying that the module has been programmed for a bell button). Simply turn the throttle off and then on again to "Lock-In" the new setting. You can also use Feature 18 to reset to its original factory (default) setting (separate bell button operation).

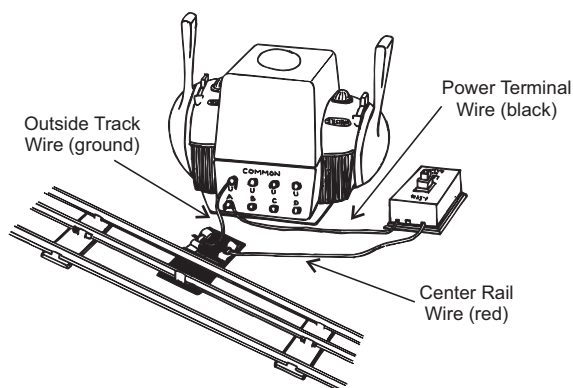

Figure 7: Wiring Up A Bell Button Controller

PROGRAMMING FOR WHISTLE IN NEUTRAL OPERATION

If you want to blow your whistle when your engine is in neutral, you will need to program ProtoSounds to do so as the factory setting only allows the whistle to blow in forward or neutral. To do this, enter RESET and go to Feature 25. (See the section entitled "Entering RESET Options" on page 15). Once in Feature 25, press the transformer whistle button and wait for ProtoSounds to sound a bell ding(s). Continue pressing the whistle button until ProtoSounds sounds two bell dings (signifying that ProtoSounds has been programmed to sound the whistle in neutral). Turn the throttle off and then on again to "Lock-In" your selection. Now, whenever you are in neutral, you can blow the whistle with the transformer whistle button. To reset ProtoSounds to its original factory setting of no whistle in neutral,

repeat the above procedure but keep pressing the whistle button in Feature 25 until ProtoSounds only dings once instead of twice.

Note: *If you didn't set the "Separate Bell Button Operation" in Feature 20 before setting the "Whistle In Neutral" option, then your bell will not function until you set the "Separate Bell Button" option. In addition, when "Whistle In Neutral" is set, the whistle will not sound in neutral if the transformer throttle setting is over 11 volts. At 11 volts or higher, ProtoSounds may arm the ProtoCoupler for operation whenever the whistle button is pressed and the engine is in neutral.*

PROGRAMMING FOR PROTOCOUPLER OPERATION

ProtoSounds now comes with a new RESET feature that allows the operator to remotely turn off the ProtoCoupler coil coupler functions. This is especially useful when double or triple-heading ProtoSound equipped engines since every engine equipped with a ProtoCoupler will fire when prompted to by the operator. By turning off the ProtoCoupler operation on certain engines, you can fire the couplers open on the other engines without uncoupling the engines from each other. To turn the ProtoCoupler function off, enter RESET and go to Feature 10. (See the section on "Entering RESET Options" on page 15). Once in Feature 10, press the transformer whistle button and wait for ProtoSound to sound a bell ding(s). Continue pressing the whistle button until ProtoSounds sounds two bell dings (signifying that the ProtoCoupler option has been turned off). Simply turn the transformer throttle off and then on again to lock in the new setting. To Reset ProtoSounds to its original factory setting of ProtoCoupler on, repeat the above procedure but keep pressing the whistle button in Feature 10 until ProtoSounds only dings once instead of twice.

PROGRAMMING FOR SQUEAKING BRAKES AND FYS OPERATION

ProtoSounds is equipped with a RESET setting to turn off the Squealing Brakes and Freight Yard Sound (FYS) features. This is especially useful if you are double-heading engines that are both equipped with FYS. You wouldn't want to stop in a freight yard and have both engines initiate their FYS sounds. To turn off Squealing Brakes and FYS (you cannot turn off one or the other), enter RESET and go to Feature 28. (See the section on "Entering RESET Options" on page 15). Once in Feature 28, press the transformer whistle button and wait for ProtoSounds to sound a bell ding(s). Continue pressing the whistle button until ProtoSounds sounds two bell dings (signifying that the Squealing Brakes and FYS have been turned off). Simply turn the transformer throttle off and then on again to lock in the new setting. To reset ProtoSounds to its original factory setting of Squealing Brakes and FYS on, repeat the above procedure but keep pressing the whistle button in Feature 28 until ProtoSounds only dings once instead of twice.

ACTIVATING REMOTE LOCK-OUT CONTROL

ProtoSound equipped engines feature a RESET setting that allows the operator to remotely “lock” the engine into forward, neutral or reverse. This is especially useful on layouts that feature “blocked” track sections. The lockout feature comes from the factory in the OFF position, meaning it is not active when you first take the engine out of the box. This is done to prevent novice operators from accidentally locking their engines into forward, neutral or reverse and then mistakingly thinking that the engine’s electronics have failed. To activate the Remote Lockout Control setting, go to RESET Feature 40 (see the section entitled “Entering RESET Options” on page 15). Once in Feature 40, press the transformer whistle button and wait for ProtoSounds to sound a bell ding. Continue pressing the whistle button until ProtoSounds sounds two bell dings signifying that the Remote Lockout Control has been selected. To lock in the setting, simply turn the throttle all the way off and then back on again. To turn the Remote Lockout Control setting back off, go back to Feature 40 and press the whistle button until only one bell ding sounds. To lock in the setting, simply turn the transformer throttle off and then back on again. Alternatively, you can go to RESET Feature 18 to reset all ProtoSound Features back to their original factory default settings, including Remote Lockout Control.

RESETTING ALL PROTO SOUND OPTIONS TO FACTORY DEFAULTS

ProtoSounds is equipped with a RESET feature (Feature 18) that resets all programmable options back to their original factory settings. This is a useful feature if you find your engine not operating the way you think it should and don’t want to take the time to check each RESET Feature one at a time. To reset all the RESET Features back to their original factory settings, enter RESET and go to Feature 18. (See the section entitled “Entering Reset Options” found on page 15). Once in Feature 18, press the transformer whistle button and wait for ProtoSounds to sound a garbled bell sound. Simply turn the transformer throttle off and then on again to lock in the setting and reset all the options back to their original factory settings.

REVERSE UNIT LOCK-OUT OPERATION

ProtoSound's unique design eliminates the need for a lock-out switch on the locomotive by allowing the customer to lock the engine into any directional state (forward, neutral or reverse) from the transformer. This will allow users to run the engine on layouts equipped with block signals or stop stations which would normally cycle the engine back into neutral. The feature must be first turned on by accessing RESET Feature 40 (See page 15).

LOCKING THE ENGINE INTO FORWARD OR REVERSE

To lock the engine into Forward or Reverse, use the transformer throttle to enter Forward or Reverse (whichever state you want to lock the engine into) and while the engine is moving press the whistle button. **WHILE THE WHISTLE IS BLOWING TURN THE THROTTLE OFF AND THEN LET GO OF THE WHISTLE BUTTON.** After about one second, you will hear a short horn blast. **QUICKLY TURN THE THROTTLE BACK ON AGAIN.** Your engine is now locked into Forward or Reverse and it will remain so until you unlock the engine, even if you wait a year to run your engine again.

UNLOCKING THE ENGINE

Unlocking the engine is a similar procedure. **WHILE THE ENGINE IS MOVING, PRESS THE WHISTLE BUTTON. WHILE THE WHISTLE IS BLOWING, TURN THE THROTTLE OFF AND THEN LET GO OF THE WHISTLE BUTTON.** After three seconds without power you will hear one chime of the RESET bell. **TURN ON THE POWER AGAIN.** Your engine is now in RESET and will operate normally once you interrupt power and enter the forward direction.

LOCKING THE ENGINE INTO NEUTRAL

To lock the engine into the NEUTRAL position, **PUT THE ENGINE IN NEUTRAL AND WITH THE THROTTLE STILL ON, PRESS THE WHISTLE BUTTON. WHILE THE WHISTLE BUTTON IS BEING PRESSED, TURN OFF THE THROTTLE AND LET GO OF THE WHISTLE BUTTON.** After about one second, you will hear a short blast of the horn. **QUICKLY TURN THE POWER BACK ON AGAIN.** Your engine is now locked into NEUTRAL.

NOTE: *When locking the engine in the Forward or Reverse positions, the whistle button will blow the horn. But when locking the engine into the NEUTRAL position, the whistle button may turn on or off sounds of the bell, coupler arming or coupler firing depending on the transformer throttle voltage settings prior to the user's attempt to lock out the engine. Remember, the horn doesn't blow in NEUTRAL (unless you programmed it to do so using Feature 25. See page 14 for details), only the bell rings or the coupler operates in NEUTRAL. While it doesn't make any difference on how the lockout function operates, you may hear one of the three different NEUTRAL-activated sounds.*

To unlock the engine from the NEUTRAL position, follow the process to unlock the engine in the Forward or Reverse directions above.

OIL & LUBRICATION INSTRUCTIONS (2 & 3-Rail Versions)

In order for the engine to perform correctly and quietly, it is important that both the locomotive and tender be lubricated before operation. Lubrication should include all side-rods and linkage components to prevent them from squeaking. Use light household oil and

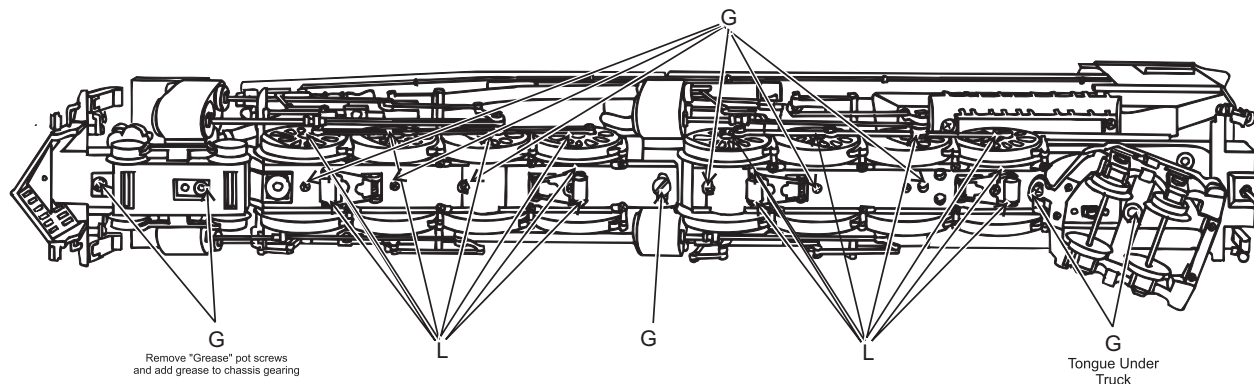

Figure 8: Lubricating The Locomotive Chassis

follow the lubrication points marked "L" in Fig. 8 above. In addition to the locomotive, the tender axles should receive a drop of oil where each axle enters the truck side frame.

The locomotive gearing has been greased at the factory and shouldn't need additional grease until after 50 hours of operation or one year whichever comes first. Grease can be added by inserting grease into the 3 grease pot screw holes (identified by the word "grease") as seen in Fig. 8 above. Once the screws are removed, grease can be applied into the holes with a grease tube dispenser. In addition to the gear box gears, it is a good idea to add grease to the leading and trailing truck mounting areas marked by "G" as shown in Fig. 8. This will enhance the engine's ability to run through O-72 "S" curves.

Periodically, check the locomotive and tender wheels for dirt build-up as this can significantly affect the engine's ability to perform properly. Dirty track and dirty wheels can cause both poor electrical contact and poor traction especially on elevated track sections. Finally, dirt and oil build-up can prematurely wear out the neoprene rubber traction tires.

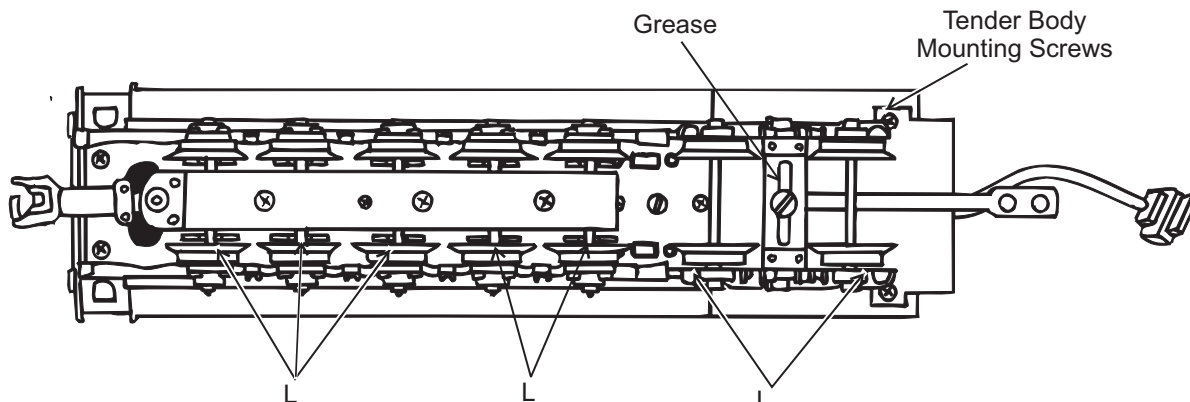

Figure 9: Lubricate The Tender Chassis Trucks Where The Axle Enters The Side Frame

TRACTION TIRE REPLACEMENT INSTRUCTIONS

Your Big Boy locomotive is equipped with four neoprene rubber traction tires. While these tires are extremely durable and long-lasting there may arise a time where they will need to be replaced. Should this occur, you will need to remove the main side rod on the 6-wheel drive train in order to slip the new tire over the wheel.

Before the new tire can be installed, you must make sure the old tire has been completely removed from the groove in the drive wheel. Use a razor blade or small flatblade screwdriver to pry the old tire remains from the groove. Once the old tire has been completely removed, slip the new tire between the main side rod and the wheel and stretch it over the wheel. You may find it useful to use two small flatblade screwdrivers to assist you in stretching the tire over the wheel. Be careful to avoid twisting the tire when stretching it over the wheel. If a twist occurs, the tire will have to be removed and reinstalled or a noticeable wobble in your engine will occur when operating the locomotive. In addition, it is important to make sure that the tire is fully seated inside the groove. Any portion of the tire extending out of the groove can cause the engine to wobble. A razor blade can be used to trim away any excess tire that doesn't seat itself inside the groove properly. Once the new tire is in place, screw the main side rod Hex screw back in place and operate as usual.

BOILER & TENDER LIGHT BULB & SMOKE UNIT REMOVAL & REPLACEMENT (2 & 3-Rail Versions)

The headlight, marker lights and backup light in both the locomotive and tender can be easily removed should they need to be replaced. Replacements are available through MTH Electric Trains. Each bulb has a quick/disconnect plug that attaches the bulb harness to a light circuit. The boiler headlight is accessed by removing the boiler from the chassis. Removal of the boiler is accomplished by removing the boiler screws as seen in Figure 10. The tender backup light plug is located inside the tender shell which must be removed from the tender chassis in order to gain access (See Figure 10 on page 20). The tender shell is attached to the tender chassis by 4 Phillips screws located on the bottom of the tender chassis. The smoke unit is accessed by following the smoke unit assembly instructions found on pages 4 and 5.

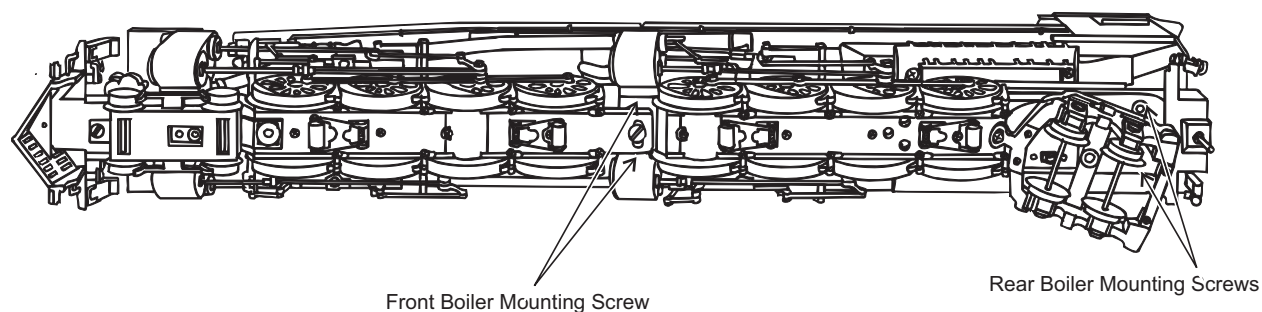

Figure 10: Removing The Boiler From The Chassis

TROUBLE SHOOTING PROTO SOUND™ PROBLEMS

Although ProtoSounds has been designed and engineered for ease of use, some questions may arise during initial operation. The following table should answer most questions. If you find that your problem can't be resolved with this manual, contact MTH ProtoSound Electronics (9693-A Gerwig Lane, Columbia, MD 21046) for additional assistance.

WHISTLE PROBLEMS	REMEDY
The WHISTLE seems distorted at low voltages.	Your battery may be undercharged or dead. Try recharging the battery as explained in the battery sections.
When I press the whistle button, the bell comes on instead.	You are trying to operate the whistle in neutral. The whistle will only operate in Forward or Reverse unless you program ProtoSounds through Feature 25. See the instructions in the section entitled "Using RESET to Program ProtoSounds".
I can't get the whistle to blow when I press the whistle button.	You may be pressing the whistle button too quickly. Most older AC transformers contain a two-step whistle button that releases a DC signal onto the track. It is this DC signal that tells the whistle to blow. However, because the signal is weaker when the whistle button is depressed fully, the ProtoSound circuit may not recognize the signal. Try pressing the whistle button slower, taking approximately 1 second to fully depress the button.
BELL PROBLEMS	REMEDY
When I press the whistle button to activate the bell, the whistle sounds.	You are trying to ring the bell in Forward or Reverse. The bell only operates in Neutral unless you have programmed ProtoSounds to recognize a separate bell button.
When I press the whistle button to activate the bell, I arm the coupler.	Reduce the voltage on the transformer before pressing the whistle button to activate the bell. The bell will only come on at 8 volts or less.
When I press the whistle button to activate the bell, the bell only rings once.	You are trying to ring the bell in RESET instead of neutral. Interrupt the power twice to enter Neutral, set the voltage at 8 volts or less and press the whistle button to activate the bell.
I can't get the bell to ring when I press the whistle button.	You may be pressing the whistle button too quickly. See the 3rd remedy in the whistle section above.
The bell won't work with a separate bell button.	ProtoSounds must be programmed in order for a separate bell button to function. Enter RESET function number 20 (see the section entitled "Using RESET to Program ProtoSounds") and press the whistle button until the bell sounds two dings. Simply turn the throttle off and then on again to lock in the new setting.
COUPLER PROBLEMS	REMEDY
The ProtoCoupler won't let the engine uncouple on the "Fly".	The power required to fire the coupler open when the engine is on the "Fly" may be greater than the ProtoSound system is capable of providing. As a result, you may experience times when the coupler won't fire open. Unfortunately, the only solution is to stop the engine and fire the coupler in Neutral. If that doesn't resolve the problem, try lubricating the coupler knuckle and rivet as explained in the ProtoCoupler Operation section.
I can't get the coupler to arm or fire open when I press the whistle button.	You may be pressing the whistle button too quickly. See the third remedy in the whistle section above. Another possibility is that ProtoSounds has been programmed to turn the coupler function off. See the section entitled "Using RESET to Program ProtoSounds".
Only one coupler will function when I press the whistle button.	Only one coupler can operate at any one time. Use the coupler selection switch on the bottom of the chassis to choose which coupler you want active.
LOCKOUT PROBLEMS	REMEDY
I can't get the engine to run after I power up the transformer. It sits still with the steam compressor sounds running.	The engine is locked out into the Neutral position. Follow the unlocking procedures in the Lockout Section.
The engine won't lock out into Forward, Neutral or Reverse even after the short whistle blast sounds.	You are waiting too long to turn the throttle back on after the short whistle blast sounds. The power must be turned back on immediately after the short whistle blast sounds or the engine will go back into RESET. See the lockout procedure in the Lockout Section.
VOLUME PROBLEMS	REMEDY
When I try to run the engine, the steam volume is OFF or very low.	The steam volume has been programmed at a reduced volume or to be silent. Go to RESET Feature 6 and adjust the volume. See the section entitled "Using RESET to Program ProtoSounds" for more information.
When I try to set the steam volume, it resets itself to the original volume after I selected the new volume.	You are trying to set the volume with a poorly charged or dead backup battery. See the section on Battery Backup for more information.
When I try to set the Steam Volume to 0 Volume, I still hear the cab chatter sounds.	When the steam volume is set to 0, you will hear the Cab Chatter sounds because setting the steam volume only controls the sound of the steam engine itself. All other sounds, including Cab Chatter, the whistle and bell will continue to play at the volume level set by the manual volume control knob located on the bottom of the chassis. See the section entitled "ProtoSound Volume Adjustment" for more information.
The sounds seem distorted, especially when the whistle or bell is activated.	The overall ProtoSound volume has been set to high creating the distorted sounds. Try turning the volume control knob located on the bottom of the chassis counter clockwise to reduce the overall volume level.
BATTERY PROBLEMS	REMEDY

I get no sounds when the engine shifts between the direction states.	The battery may be dead or needs charging. See the Battery Backup section for more information.
After I turn off my transformer, my engine continues to make sounds before quitting with a ding of its bell.	ProtoSounds continues to sound for approximately 10 seconds after power to the track has been shut off.
The sounds distort at low voltages.	The battery is insufficiently charged or dead. Follow the recharging instructions found in the section entitled "Self Recharging Battery Backup System".
A repeating whistle blast occurs after the power has been shut down.	The battery is insufficiently charged or dead. Follow the recharging instructions found in the section entitled "Self Recharging Battery Backup System".

RESET PROBLEMS

REMEDY

When I first turn the power on, the engine will not begin to run. I have to turn the throttle off and then on again to get the engine to operate.	This is normal behavior. When power to the track is first turned on, ProtoSounds enters a "RESET" phase at which time the engine undergoes a system check. Power must be interrupted to get the engine into the Forward Phase. See the section entitled "DCRU Reverse Unit Operation" for more information.
Whenever I interrupt the power from RESET to enter Forward, the engine goes back into RESET instead of Forward. I know this occurs because the bell dings twice.	Whenever ProtoSounds enters RESET after power has been off for more than 15 seconds, the microprocessor initiates a system check to determine that everything is in working order. This system check requires 2.2 seconds to complete during which time the engine will play the steam startup sounds. We recommend that you don't interrupt the power in RESET until the steam startup sounds have completed. This will guarantee that the system check will have been completed since the startup sounds take longer than 2.2 seconds to play. If the problem persists, we recommend that you operate the throttle with a slower movement as you interrupt the power in RESET and enter the Forward Phase.

BRAKE SOUND PROBLEMS

REMEDY

When the transformer is throttled down, the sounds won't play.	The brake feature has not been activated. See the section on activating the brake feature for more information. The throttle voltage setting on the transformer is either not starting high enough or ending low enough to trigger the brakes sounds. Try increasing the throttle setting to 14 volts or higher before throttling down to 8 volts or less.
The brake sounds continue to play even after the engine stops.	The brake feature sound record lasts for three seconds. With practice you can control how quickly you should stop the engine to keep it in sequence with the sound of the brake's squeaking.
The brake feature was activated in neutral after the engine was running in forward, but the brake sounds would not play when triggered after the engine went back into forward or reverse.	The brake feature will only remain enabled if it is triggered in the first direction state you enter after activating the feature in neutral. You cannot interrupt the power twice to enter another direction state and still have the brake feature active. Therefore, in order to make the brake sound feature operate in forward, you must first activate the feature in the neutral position that occurs after the engine was in the reverse state.
After triggering the brake sound and stopping the engine in neutral, the engine begins making passenger station sound effects.	After you trigger the brake sounds, you cannot stop the engine in neutral and leave the track power on without activating the passenger station sounds. If you don't want to hear the passenger station sounds after entering neutral, turn the power off for three seconds to disable the passenger station sound effects.

FYS PROBLEMS

REMEDY

The FYS feature does not begin even after stopping the engine and hearing the brake sounds.	The power was not turned back on once the engine enters the neutral state thus disabling FYS. The transformer throttle was interrupted too quickly in neutral thus disabling FYS. Leave the throttle on in neutral until after the FYS arrival message plays.
The FYS sound effects occasionally repeat themselves.	ProtoSounds has a built-in random number generator that randomly selects each sound clip to play. Because there are only a total of 8 sound clips available in each FYS event, it is probable that a sound can occasionally be repeated one or more times.
Once in FYS, the engine never goes in reverse.	So that the passenger station sound effects and operation is as realistic as possible, ProtoSounds disables the reverse unit state whenever FYS is enabled. This way the engine never goes into reverse as the operator cycles through the various FYS events.
When the engine enters FYS event 5, the bell automatically comes on.	FYS has a built-in command to turn on the bell when the system enters Event 5. After approximately 15 rings of the bell, it automatically will turn off.
Whenever FYS is enabled, pressing the whistle and bell buttons has no affect	Because FYS must control various effects in each FYS event, the bell and whistle functions are disabled until either the FYS events have been completed, or the engine is shut down for 3 or more seconds.
I can't get FYS to begin when the engine is stopped in the neutral position.	It is possible that FYS was never enabled or has been disabled. Try reactivating the feature by holding down the bell button for three or more seconds.

TRANSFORMER COMPATIBILITY AND WIRING CHART

ProtoSounds™ is designed to work with any “Standard” AC transformer that uses a “Pure Sine-Wave” format. The chart below details how the terminals on these compatible transformers should be attached to your layout. The Trainmaster System from Lionel® (marked with an * below) will not function correctly with ProtoSound without disrupting the sound effects. Therefore, ProtoSounds is designed to sense whenever a non-compatible transformer (like the Trainmaster) is being used and then automatically disables the ProtoSound sound effects giving the operator control over the engine direction only.

Transformer Type	Outside Rail	Center Rail	Min/Max Voltage	Power Rating
Lionel 1032	A	U	5-16v	90-Watt
Lionel 1032M	A	U	5-16v	90-Watt
Lionel 1033	A	U	5-16v	90-Watt
Lionel 1043	A	U	5-16v	90-Watt
Lionel 1043M	A	U	5-16v	90-Watt
Lionel 1044	A	U	5-16v	90-Watt
Lionel 1053	A	U	8-17v	60-Watt
Lionel 1063	A	U	8-17v	60-Watt
Lionel LW	U	A	8-18v	75-Watt
Lionel KW	U	A or B	6-20v	190-Watt
Lionel RW	A	U	9-19v	110-Watt
Lionel SW	A	U	Unknown	130-Watt
Lionel TW	A	U	8-18v	175-Watt
Lionel ZW	U	A-D	8-20v	275-Watt
Right of Way	Black	Red	0-25v	600-Watt
Lionel RS-1	Black	Red	0-16v	50-Watt
Lionel Trainmaster*	U	A	See Transformer Instructions	See Transformer Instructions
ALL-Trol Walk-Around	See Transformer Instructions	See Transformer Instructions	See Transformer Instructions	See Transformer Instructions
MRC Tech II	Variable AC	Variable AC	0-17v	40Va
DALLEE Hostler	See Transformer Instructions	See Transformer Instructions	0-16v	160-Watt

PROTOSOUND RESET FEATURE CHART

The following chart lists the available features found in your ProtoSound equipped engine. The default settings are listed for each feature as well as the operation of the feature. You can reset all features to their original factory settings by accessing Feature 18 in RESET and pressing and holding the transformer whistle button until you hear a soft, warbled bell sound.

RESET #	OPERATION	DEFAULT SETTING	CLINKS\CLANKS
6	Diesel Volume	Full Volume	5 Clinks\1 Clank
10	Coupler On\Off	Coupler On	0 Clinks\2 Clanks
18	Reset Default Settings		3 Clinks\3 Clanks
20	Remote Bell Button	Bell Button Active	0 Clinks\4 Clanks
23	RESERVED	RESERVED	
25	Whistle In Neutral	Whistle In Neutral Off	0 Clinks\5 Clanks
27	Chuff Rate	Full Chuff Range	2 Clinks\5 Clanks
28	Brake\FYS Enabled	Brake\FYS ON	3 Clinks\5 Clanks
40	Lockout Enabled	Lockout OFF	8 Clanks

SERVICE AND WARRANTY INFORMATION

HOW TO GET SERVICE UNDER THE TERMS OF THE LIMITED ONE YEAR WARRANTY

For warranty repair, do not return your product to the place of purchase. Instead, follow the instructions below to obtain warranty service as our dealer network is not prepared to service the product under the terms of this warranty.

1. First, write, call or FAX MTH Electric Trains, 9693-A Gerwig Lane, Columbia, MD 410-381-2580, 410-381-6122(FAX), stating when it was purchased and what seems to be the problem. You will be given a return authorization number to assure that your merchandise will be properly handled upon its receipt.
2. CAUTION: Make sure the product is packed in its original factory packaging including its foam and plastic wrapping material so as to prevent damage to the merchandise. The shipment must be prepaid and we recommend that it be insured. A cover letter indicating the reason for the return and a brief description of the problem should be included to facilitate the repairs. Please don't forget to include your return name and address.
3. Please make sure you have followed the instructions carefully before returning any merchandise for service.

LIMITED ONE YEAR WARRANTY

This item is warranted for one year from the date of purchase against defects in material or workmanship. We will repair or replace (at our option) the defective part without charge for parts or labor, if the item is returned to the address below within one year of the original date of purchase. This warranty does not cover items that have been abused or damaged by careless handling. Transportation costs incurred by the customer are not covered under this warranty.

This warranty gives you specific legal rights and you may have other rights which vary from state to state.