



Premier R-1 Subway Set

OPERATOR'S MANUAL (3V PS-2)

Compatibility

This engine will operate on any traditional O-31 Gauge track system, including M.T.H.'s RealTrax® or ScaleTrax™ or traditional tubular track. It is also compatible with most standard AC transformers. (See page 22 for a complete list of compatible transformers and wiring instructions.)

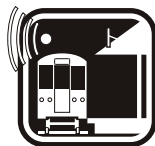

Transit Announcement Stop

PLEASE READ BEFORE USE AND SAVE

Table of Contents

Set Up Checklist.....	3
Lubrication.....	3
Checking the Battery.....	3
Basic Operation.....	4
Activating Features.....	4
Lighting Options.....	6
Proto-Sound 2.0 Operating Instructions.....	7
Activating Proto-Sound 2.0 Conventional Mode Features.....	7
Transit Announcement Stops (TAS).....	8
Proto-Coupler® Operation.....	11
Speed Control.....	12
Locking Locomotive Into A Direction.....	13
Reset To Factory Default.....	13
Automatic Sound Effects.....	13
Maintenance.....	14
Lubricating and Greasing Instructions.....	14
Cleaning The Wheels, Tires and Track.....	15
Lightbulb Replacement Instructions.....	16
Self Charging Batter Back-Up.....	18
Tire Traction Replacement.....	19
Troubleshooting Proto-Sound® 2.0 Problems.....	21
Transformer Compatibility and Wiring Chart.....	22
Additional Features Accessible with the DCS Remote Control System...	23
Service & Warranty Information.....	24
Limited One-Year Warranty.....	24

CAUTION: ELECTRICALLY OPERATED PRODUCT:

Not recommended for children under 10 years of age. M.T.H. recommends adult supervision with children ages 10 - 16. As with all electric products, precautions should be observed during handling and use to reduce the risk of electric shock.

WARNING: When using electrical products, basic safety precautions should be observed, including the following: Read this manual thoroughly before using this device.

- M.T.H. recommends that all users and persons supervising use examine the hobby transformer and other electronic equipment periodically for conditions that may result in the risk of fire, electric shock, or injury to persons, such as damage to the primary cord, plug blades, housing, output jacks or other parts. In the event such conditions exist, the train set should not be used until properly repaired.
- Do not operate your layout unattended. Obstructed accessories or stalled trains may overheat, resulting in damage to your layout.
- This train set is intended for indoor use. Do not use if water is present. Serious injury or fatality may result.
- Do not operate the hobby transformer with damaged cord, plug, switches, buttons or case.

This product may be protected by one or more of the following patents:
6,019,289; 6,280,278; 6,281,606; 6,291,263; 6,457,681; 6,491,263; 6,604,641;
6,619,594; 6,624,537; 6,655,640.

Set Up Checklist

- Lubricate the locomotive
- Check to see whether the battery needs to be charged for full sound effects
- Apply power to run as described in the Basic Operating Section of this manual

Lubrication

You should lubricate the engine to prevent it from squeaking. Use light household oil and follow the lubrication points marked "L" in Fig. 1. Do not over-oil and avoid getting lubricant on flat surface of pickup roller. Use only a drop or two on each pivot point.

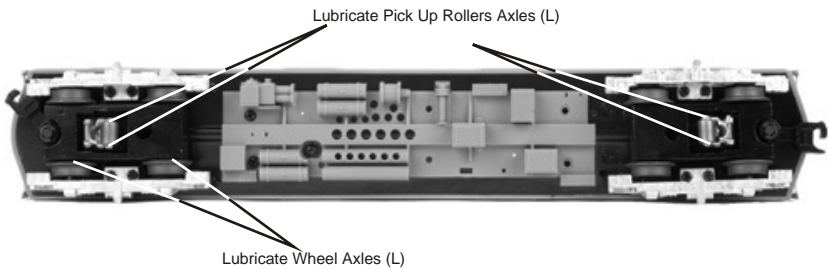

Figure 1. Lubrication Points on the Locomotive

Checking the Battery

You may find, if your locomotive was built several months before you set it up, that the rechargeable battery has run down and needs to be charged before operating. If you notice that the sounds are garbled, test and charge the engine as described in the "Self-Charging Battery Back-Up" on page 18.

Basic Operation

Activating Features

Throttle - Throttle up the power to your track. Advance the throttle until 12 – 16 volts is applied, then put the subway set into forward motion by either firmly pressing the Direction button on your transformer or remote once or dropping and advancing the throttle.

Bell - To sound the bell, in an engine equipped with a bell firmly press and release the Bell button. To turn the bell off, press and release the Bell button again. The bell will continue to ring from the time you turn it on until you press and release the button again to turn it off.

Horn/Whistle - To sound the horn, firmly press the Horn/Whistle button. The horn will sound for as long as you continue to depress the button. It will stop when you release the button. The horn has four different endings, depending on whether you hold the button for less than three seconds, three seconds, four seconds, or five seconds or longer.

Direction - Your train is programmed to start in neutral. The first direction from neutral upon start-up is forward. Firmly press and release the Direction button to allow the engine to move forward. Just as you must stop your automobile between forward and reverse, this engine will not go directly from forward to reverse; it goes into neutral between directions. If the train has been moving forward, the first press of the Direction button will put the train from forward into neutral, the second press into reverse, the third press back into neutral, and the fourth back into forward. To prevent accidental high-speed start-ups, this engine is programmed to restart in neutral each time the track voltage is turned off for approximately 25 seconds or more.

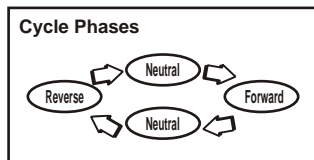

Manual Volume Control

To adjust the volume of all sounds made by this engine, turn the master volume control knob located under the powered unit (See Figure 2) clockwise to increase the volume and counter-clockwise to decrease the volume.

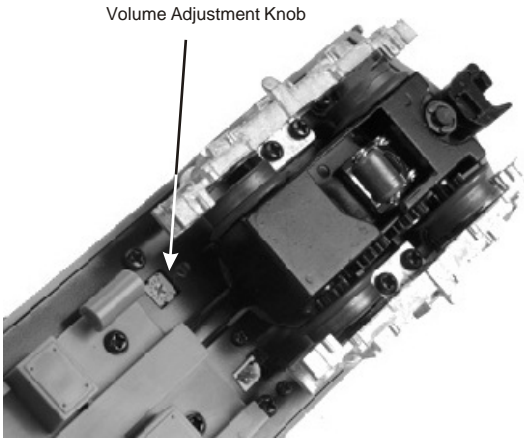

Figure 2. Manual Volume Adjustment Knob

Lighting Options

The powered and rear units are equipped with different lighting options you can select manually.

Powered Unit

To light the “Express” train sign, slide the EXP/LOC switch on the bottom of the car to “EXP.”

To light the “Local” train sign, slide the EXP/LOC switch to “LOC.”

Rear Unit

To turn the headlight on, as if the rear car were at the head of the train, slide the ON/OFF switch on the bottom of the car to the ON position..

To light the “Express” train sign, slide the EXP/LOC switch on the bottom of the car to “EXP.”

To light the “Local” train sign, slide the EXP/LOC switch to “LOC”.

Proto-Sound 2.0 Operating Instructions

This manual contains the operating instructions for Proto-Sound 2.0 in conventional mode only. Instructions for accessing DCS command mode features accompany the DCS Remote Control System equipment.

Activating Proto-Sound 2.0 Conventional Mode Features:

Because Proto-Sound 2.0 is an all-new system developed by M.T.H.'s own research and development team, it operates differently from original Proto-Sound. Most Proto-Sound 2.0 features are automatically enabled, and Reset has been eliminated, so there is no need to program features as with original Proto-Sound. Although the new system is easier to operate than original Proto-Sound, you should read these instructions thoroughly before using Proto-Sound 2.0 features in order to prevent harm to yourself or your equipment.

Proto-Sound 2.0 features are activated by sequences of Bell and Horn button pushes described below. Please read the full descriptions of each feature before using it. To use these buttons to activate features rather than to blow the horn or ring the bell, you should press the buttons firmly, but rapidly with a 1/2-second pause between button presses. You may need to practice your timing to make this work smoothly.

Timing Chart				
Press Whistle Short & Firm	1/2 Sec. Pause	Press Bell Short & Firm	1/2 Sec. Pause	Press Bell Short & Firm
Total Time Lapse: 1 1/2 Seconds				

Operating Modes

1. Manual Mode

Upon initial power application, the engine will start up in manual mode. The chart below lists the features available to the operator when in Manual Mode. Different features are available when operating in Learn and Auto Modes, which are described later.

Feature to Be Activated	Button Code:
Transit Announcement Sounds (TAS)	1 Bell (depress button approx. 2 secs.)
Speed Control On/Off	1 Horn, 2 Bells (from neutral only)
Lock into a Direction	1 Horn, 3 Bells
Reset to Factory Defaults (including	1 Horn, 3 Bells
default Auto Mode route settings)	1 Horn, 5 Bells (from neutral only)

Transit Announcement Sounds (TAS)

Your Proto-Sound 2.0 street car is equipped with operator controlled Transit Announcement Sounds, hereafter known as TAS. This easy-to-use feature plays digitally reproduced transit announcements and platform action sounds whenever you activate and stop your engine. No additional wires or modifications are needed on your layout to enjoy these amazing sound effects. These different sounds are heard each time you give a long bell button press. The entire TAS sequence is designed to simulate the arrival, disembarking, embarking, and departure of a transit stop. The sounds include the driver announcing the stop and the upcoming stop, passenger disembarking and embarking sounds, driver to passenger requests, door openings and closing and general transit stop sounds. After the station sounds have finished, the engine will shift back into gear and, if the throttle is set high enough, will pull away from the station.

To activate the TAS, press and hold the bell button for approximately 2 seconds.

If you do not wish to stop at the station that is announced after activating TAS, press and hold the bell button again without throttling down the train.

2. Learn Mode

In Learn Mode, the engine may be programmed with either an "Out & Back" route or a "Loop" route. An "Out & Back" route begins at the 1st station (as programmed by the operator), stops at intermediate stations, ends at the last station, then reverses its route until it reaches the 1st station. A "Loop" route begins at the 1st station (as programmed by the operator), stops at intermediate stations, ends at the last station, and then begins the route over again at the 1st station.

Example Of An Out-and-Back:

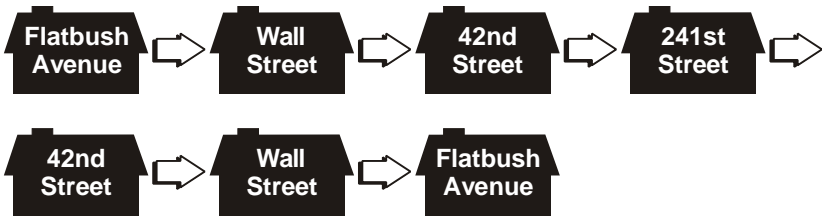

Example Of A Loop:

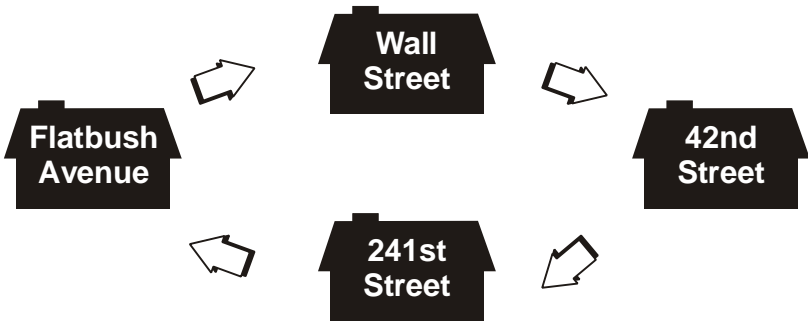

To program stations:

1. Running in Forward, stop the unit at the desired location for the first stop by pressing the direction button. Note: if you stop the engine with the throttle control, you must re-apply

2. Enter Learn Mode by pressing Horn-Bell-Bell-Bell-Bell. The train will then announce that you have entered Learn Mode.
3. Press and hold the Bell button to scroll through the available stations until you hear the one that you would like to be your first stop. Release the button quickly as soon as you have heard the desired stop name.
4. Press and hold the Horn button until a "saved" response confirms that station's location and name are saved in memory.
5. Proceed to the next stop by pressing the Direction button.
6. Press the Direction button to stop the train again when you have reached the next desired station location.
7. Using the Bell button, select the name of the station, then save using the Horn button.
8. Repeat steps 5-7 until you are ready to program the last stop in the route.
9. The manner of saving the last station in the route determines whether the route will be an "Out & Back" or "Loop" route.

"Out & Back"

Follow steps 5-7 to save the last station. After you press the Horn button and the sound system plays the "Saved" confirmation, press the Horn button again. Another "Saved" confirmation will play and the car will exit Learn Mode and enter Manual Mode.

"Loop"

Follow steps 5-7 to save the last station. Press the Direction button once to start the car in forward and stop the car at the location of the first stop by pressing the Direction button. Press the Bell button as many times as is necessary to hear the name of the first stop. Press the Horn button until the "Saved" confirmation is played. The car will then automatically exit Learn Mode and enter Manual Mode.

Notes:

Always approach a desired station stop location while running in Forward. Learn mode counts distance traveled, not actual physical locations. However, unlike an automobile's odometer, Proto-Sound 2.0 Learn Mode does erase distance when traveling in reverse. If you operate your car past the desired stop location, you may back it up to the desired stop location, however you must put the car into forward and then neutral again before saving the stop name and location into memory.

Auto Mode

When you have finished programming your stations in Learn the car will be in Manual Mode. Running in Forward, stop the car at the location of the first programmed station by pressing the Direction button. Press Bell-Horn-Horn to put the train into Auto Mode. Press the Direction button again to begin operation in Auto Mode. Because Auto Mode operation begins at the first stop, the next stop announced will be the second stop.

Function Learn Mode	Button Code:
To Enter Learn Mode	1 Horn, 4 Bells
To Stop at Each Station	Direction
To Scroll through the Station Names	Bell (hold to scroll and release as soon as you hear the desired station name)
To Save Station	Horn (hold for "Saved" response)
Function Auto Mode	Button Code:
To Enter Auto Mode from Manual Mode	1 Bell, 2 Horn at the location of the first programmed station stop
To Begin Programmed Run	Direction
Function Manual Mode	Button Code:
To Enter Manual Mode from Auto Mode	1 Bell, 2 Whistles

Proto-Coupler® Operation

This locomotive is equipped with one coil-wound Proto-Coupler for remote uncoupling action. Because Proto-Couplers are controlled through the Proto-Sound 2.0 microprocessor, they do not require an uncoupling track section or modification to your layout to function. You can fire a coupler from neutral or while in motion. Use the code shown below (and in the chart on p. 7) to fire the coupler(s).

Front Coupler:

To fire the front coupler (if your engine has one), quickly tap the Bell button once followed by four quick taps of the Horn button, allowing approximately ½ second to lapse between each quick button press. The sound of the liftbar and air line depletion will play, and the knuckle will be released.



Speed Control

M.T.H. engines equipped with Proto-Sound 2.0 have speed control capabilities that allow the engine to maintain a constant speed up and down grades and around curves, much like an automobile cruise control. You can add or drop cars on the run, and the engine will maintain the speed you set.

While the engine is programmed to start with the speed control feature activated, you can opt to turn it off. This means the engine's speed will fall as it labors up a hill and increase as it travels downward. It is also affected by the addition or releasing of cars while on the run. Because the engine will run more slowly at a given throttle voltage when speed control is on than when it is off, you should adjust the throttle to a lower power level for operation with speed control off to avoid high-speed derailments. When speed control is off, the volume will drop to allow for better low voltage operation.

To turn speed control on and off, put the engine in neutral, then quickly tap the transformer's Horn button one time then quickly tap the Bell button two times, allowing approximately ½ second to lapse between each quick button press. Two horn blasts will indicate that the engine has made the change. Repeat the 1 horn, 2 bells code to return it to the other condition. You will want to do this during the initial neutral upon start-up if you ever couple this engine to another engine that is not equipped with speed control to avoid damaging the motors in either engine. Each time you shut down the engine completely, it will automatically turn speed control on.



Locking Locomotive Into A Direction

You can lock your engine into a direction (forward, neutral, or reverse) so that it will not change directions. To do this, put the engine into the direction you want (or into neutral to lock it into neutral), run it at a very slow crawl (as slowly as it will move without halting), and quickly but firmly tap the Horn button once followed by three quick taps of the Bell button, allowing approximately 1/2 second to lapse between each quick button press. Two horn blasts will indicate that the engine has made the change. The engine will not change direction (including going into neutral) until you repeat the 1 horn, 3 bells code to return the engine to its normal condition, even if the engine is kept without power for extended periods of time.



Reset to Factory Default

To override the settings you currently have assigned to the engine and reset it to its factory defaults, while in Neutral tap the Horn button quickly once, followed by five quick taps of the Bell button, allowing approximately 1/2 second to lapse between each quick button press. Two horn blasts will indicate that the engine has made the change.



Automatic Sound Effects

Certain Proto-Sound 2.0 sound effects automatically play in programmed conventional mode conditions:

- Squealing Brakes play any time the engine's speed decreases rapidly.
- Platform Action sounds play at random intervals when the engine idles in neutral.
- Engine Start-up and Shut-down sounds play when the engine is initially powered on or is powered off for five seconds or more.

Maintenance

Lubricating and Greasing Instructions

The engine should be well oiled and greased in order to run properly.

Regularly lubricate all axles and pickup rollers to prevent squeaking. Use light household oil, such as that found in M.T.H.'s maintenance kit. Do not over oil. Use only a drop or two on each pivot point.

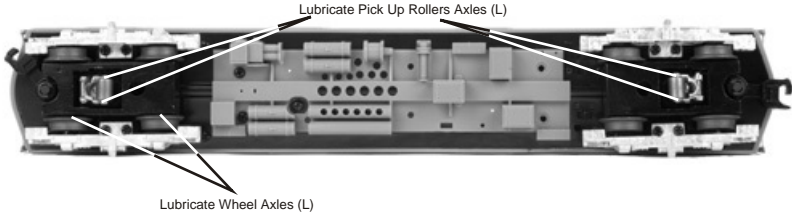

Figure 3. Lubrication Points on the Locomotive.

The locomotive's internal gearing was greased at the factory and should not need additional grease until after 50 hours of operation or one year, whichever comes first. Follow the greasing instructions below. Note that in some tightly packed engines you may need to move internal components temporarily in order to access the gears.

1. Remove the Phillips screws from the chassis, as seen in Figure 4, then lift the body away from the chassis.

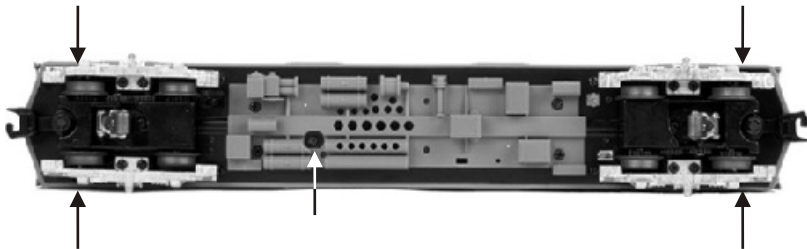

Figure 4. Body Mount Screw Locations.

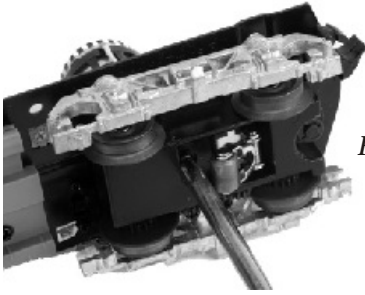

Figure 5. Removing Motor Mount Screw

2. Remove the truck blocks from the chassis by unscrewing the black Phillips motor mount screw on the bottom of each truck block, as shown in Figure 5.

3. Once the motor mount screw has been removed, pull the motor away from the truck block and lightly coat the motor worm gear and bronze drive gear (in the truck block) with grease. (Figure 6)

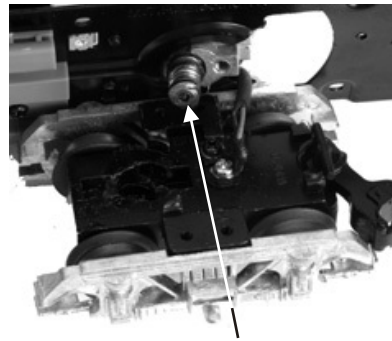

Figure 6

Lubricate Worm Gear

4. Reassemble the truck and motor, being careful not to pinch any wires between the truck block and motor mount.

5. Repeat the procedure for the other motor and truck.

6. Reassemble the chassis and body, being careful that the wires are not caught between the body and chassis, as this can lead to a short that may damage the electronics beyond repair

7. Before replacing body mount screws, test the unit on powered track to make sure all light housings are in place and functioning.

Cleaning The Wheels, Tires and Track

Periodically check the locomotive wheels and pickups for dirt and buildup, which can cause poor electrical contact and traction and prematurely wear out the neoprene traction tires. Wheels and tires can be cleaned using denatured (not rubbing) alcohol applied with a cotton swab.

To clean the track, use RailKing Track Cleaning Fluid or denatured (not rubbing) alcohol and a clean rag. Unplug the transformer and wipe the rails of the track, turning the rag frequently to ensure that you are using clean cloth on the rails.

Lightbulb Replacement Instructions

Interior Lights

To replace the interior lights in the powered unit:

1. Follow the shell removal instructions found in the “Lubricating and Greasing” section of this booklet.
2. Pull bulb housing straight out to the side, then pull bulb straight out to remove.
3. Insert new bulb into socket and reinstall.

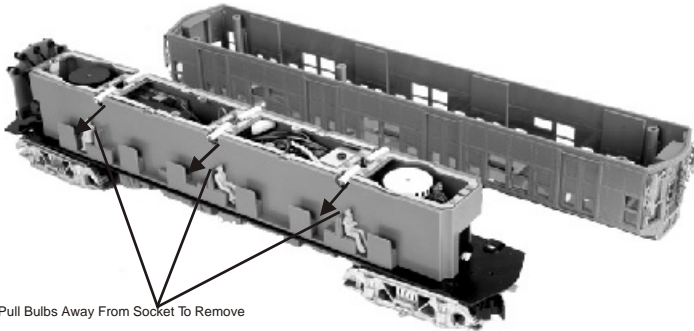

Gently Pull Bulbs Away From Socket To Remove
Figure 7

To replace the interior lights in the non-powered unit:

1. Follow the shell removal instructions found in the “Lubricating and Greasing” section of this booklet.
2. Pull bulb housing forward from its socket, and pull bulb out.
3. Insert new bulb into socket and reinstall in shell.

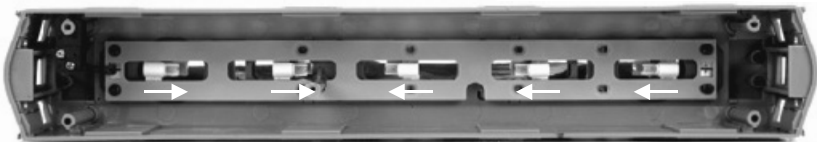

Figure 8

Headlights

To replace the headlights and other end-of-car lights in the powered unit:

1. Remove the shell as described in the “Lubricating and Greasing” section of this booklet.

2. Remove the shield around the electronics by removing the 4 screws from the bottom.(Figure 9)

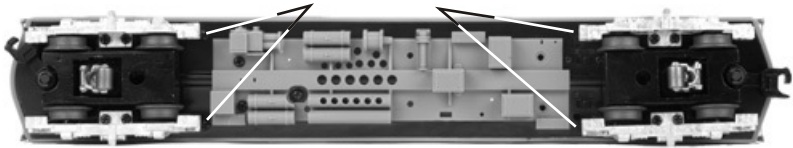

Figure 9

3. Cut the wire ties bundling the wires together on either side of the motor, pull out the bulb(s) you need to change, unplug their wires from the two-pin connector, and replace entire unit.

4. Re-tie wires and replace shield, making sure the light control switch fits properly through its slot and wires are not pinched under the shield.

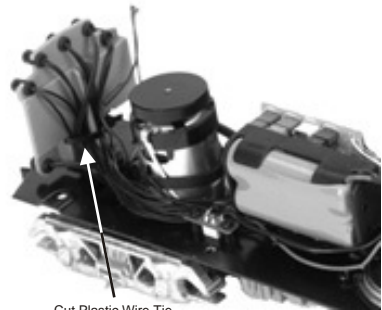

Figure 10

To replace the headlights and other end-of-car lights in the rear unit:

1. Remove the shell as described for the interior lights, above.
2. Remove the two screws holding the shield to the floor. (Figure 11)

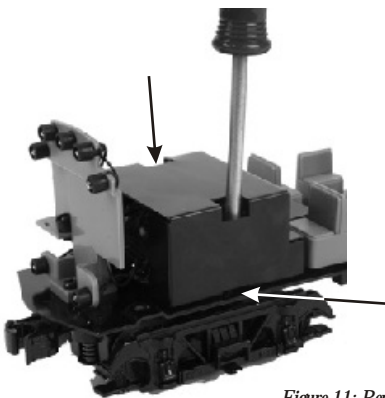
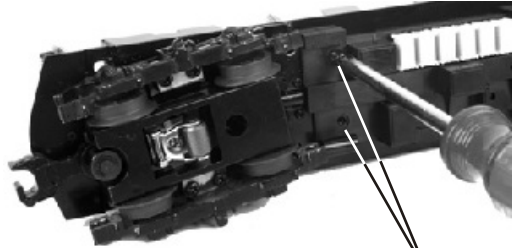

Figure 11: Remove the Shield Mount Screws

3. Remove the screws holding the front end of the interior seats to the floor. (Figure 12)

4. Lift the shield from the floor to reveal the board, light wiring and connectors..

5. Pull out the bulb(s) you need to change, unplug their wires from the two-pin connector, and replace entire unit.



Remove Interior Seats Mounting Screws
Figure 12

Replace shield and boards exactly as they were located before, making sure the light control switches fit properly through their slots and wires are not pinched under the shield.

Replacement bulbs and wire ties are available directly from the M.T.H. Parts Department (order online: www.mth-railking.com, e-mail: parts@mth-railking.com; mail: 7020 Columbia Gateway Drive, Columbia MD 21046-1532, FAX: 410-381-6122).

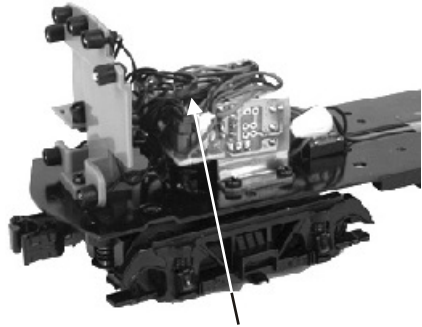

Unhook Wires, Remove And Replace Bulbs

Figure 13

Self Charging Battery Back-Up

The special NiCad 2.4v self-charging battery pack recharges continuously during train operation and should last for up to five years. The battery is a dry battery that should not leak or cause any damage to your engine. Depending upon when your engine was built, it may need to be charged right out of the box. If engine sounds seem distorted or garbled at low voltages or become silent when power from the transformer is turned off, test the battery to determine whether it should be recharged or replaced.

Test: Put the engine in neutral and leave the track voltage at 10-12 volts (high enough for

Use M.T.H.'s battery recharger (sold separately) that plugs into a wall outlet and a special port under the engine to recharge the battery overnight without leaving it on the track.

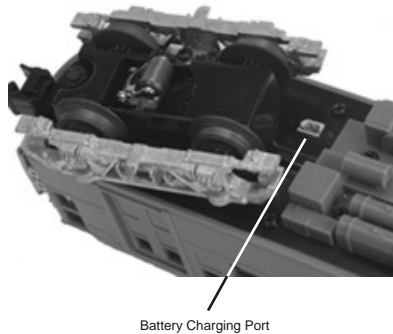

Figure 14

Replace: If the sounds are not improved at the end of the 15-minute test charge, it is time to replace the battery. M.T.H. part number available through M.T.H. Parts. See parts list at the back of this manual or on M.T.H.'s website www.railking.com.

Traction Tire Replacement

Your subway set is equipped with two neoprene rubber traction tires on each powered truck block. While these tires are extremely durable, you may need to replace them at some point.

First, remove the truck sides from the truck block. To do this turn your engine upside down and remove the truckside mounting screws as seen in Figure 15.

Once the truck sides have been removed:

1. Make sure the old tire has been completely removed from the groove in the drive wheel, using a razor blade or small flathead screwdriver to pry away any remains.

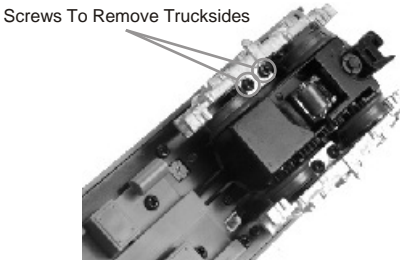

Figure 15

2. Slip the new tire onto the wheel. You may find it useful to use two small flathead screwdrivers to stretch the tire over the wheel.

3. If you twist the tire while stretching it over the wheel, you will need to remove and reinstall the tire. Otherwise your engine will wobble while operating.

4. Make sure the tire is fully seated inside the groove. Use a razor blade to trim away any excess tire that doesn't seat itself inside the groove properly.

5. Reassemble in reverse order.

One set of replacement tires is packaged with the model. Additional tires are available directly from the M.T.H. Parts Department (order online: www.mth-railking.com, e-mail: parts@mth-railking.com; mail: 7020 Columbia Gateway Drive, Columbia MD 21046-1532, FAX: 410-381-6122).

Troubleshooting Proto-Sound® 2.0 Problems

Although Proto-Sound 2.0 has been designed and engineered for ease of use, you may have some questions during initial operation. The following table should answer most questions. If your problem cannot be resolved with this table, contact M.T.H. for assistance (telephone: 410-381-2580; fax: 410-423-0009; service@mth-railking.com, 7020 Columbia Gateway Drive, Columbia MD 21046-1532).

Starting Up	Remedy
When I press the horn button, the bell comes on instead.	That is normal for this model.
I can't get any sound to play when I press the horn button.	You may be pressing the button too quickly to trigger the bell. Try pressing the horn button more slowly, taking approximately one full second to fully depress the button.
Bell	Remedy
When I press the bell button, I get a station stop announcement, not the bell.	You are holding the bell button too long. Press it for only about one second to trigger the bell.
Coupler	Remedy
When I try to fire the coupler, TAS starts.	You are waiting too long between horn button presses.
The Proto-Coupler won't let the engine uncouple on the fly.	Try lubricating the coupler knuckle and rivet with a dry graphite lubricant.
The coupler does not fire or stay coupled.	The coupler needs to be cleaned. Wipe with denatured alcohol (not rubbing alcohol) and let dry.
Platform Action Sounds	Remedy
Sometimes the Platform Action Sounds don't play.	Platform Action Sounds play only in neutral at random intervals.
Lock-out	Remedy
I can't get the engine to run after I power up the transformer. It sits still with the diesel and compressor sounds running.	The engine is locked into the neutral position. Follow the procedure in the "Lock into a Direction" section.
The engine won't lock into forward, neutral, or reverse.	Engine speed must be below 10 scale mph (approx. 10 volts or less in conventional mode).
Volume	Remedy
The sounds seem distorted, especially when the horn or bell is activated.	Proto-Sound 2.0 volume is set too high. Turn the volume control knob on the bottom of the chassis counter-clockwise to reduce the volume.
No Sound	Volume is set too low, adjust volume control knob on the bottom of the chassis clockwise to increase the volume or check connector to speaker.
Battery	Remedy
The engine will not leave the initial neutral setting.	Check to be sure the battery is installed and fully charged. See the "Self-Charging Battery Back-Up" section.
I get no sounds when the engine shifts between directions.	The battery may be dead or need to be charged. See the "Self-Charging Battery Back-Up" section.
After I turn off my transformer, my engine continues to make sounds before quitting.	Proto-Sound 2.0 is designed to continue to sound for a few seconds after power to the track has been shut off to allow for a more realistic shut-down.

Transformer Compatibility and Wiring Chart

Proto-Sound 2.0 is designed to work with most standard AC transformers. The chart below lists the many compatible transformers. Note that many of the operational commands described in these instructions require a bell button, so if your transformer does not have its own bell button, you should consider adding one to get the full benefit of the system. In addition, the chart details how the terminals on these transformers should be attached to your layout.

Transformer Model	Center Rail	Outside Rail	Min/Max. Voltage	Power Rating	Transformer Type
MTH Z-500	Red Terminal	Black Terminal	0-18v	50-Watt	Electronic
MTH Z-750	Red Terminal	Black Terminal	0-21v	75-Watt	Electronic
MTH Z-1000	Red Terminal	Black Terminal	0-14v 0-18v	80-Watt 100-Watt	Electronic
MTH Z-4000	Red Terminal	Black Terminal	0-22v	300-Watt	Electronic
Lionel 1032	U	A	5-16v	90-Watt	Standard
Lionel 1032M	U	A	5-16v	90-Watt	Standard
Lionel 1033	U	A	5-16v	90-Watt	Standard
Lionel 1043	U	A	5-16v	90-Watt	Standard
Lionel 1043M	U	A	5-16v	90-Watt	Standard
Lionel 1044	U	A	5-16v	90-Watt	Standard
Lionel 1053	U	A	8-17v	60-Watt	Standard
Lionel 1063	U	A	8-17v	60-Watt	Standard
All-Trol	Left Terminal	Right Terminal	0-24v	300-Watt	Electronic
Dalree Hoelder	Left Terminal	Right Terminal			Electronic
Lionel LW	A	U	8-18v	75-Watt	Standard
Lionel KW	A or B	U	6-20v	190-Watt	Standard
Lionel MW	Outside Track Terminal	Inside Track Terminal	5-16v	50 V.A.	Electronic
Lionel RS-1	Red Terminal	Black Terminal	0-18v	50 V.A.	Electronic
Lionel RW	U	A	9-19v	110-Watt	Standard
Lionel SW	U	A	Unknown	130-Watt	Standard
Lionel TW	U	A	8-18v	175-Watt	Standard
Lionel ZW	A, B, C or D	U	8-20v	275-Watt	Standard
Lionel Post-War Celebration Series ZW	A, B, C or D	Common	0-20v	135/190 Watt	Electronic

*Conventional Mode Only

Additional Features Accessible With The DCS Remote Control System

Additional equipment required)

While conventional mode operation of a Proto-Sound 2.0 engine yields wonderfully realistic sound and several train control features, command mode operation allows the user to access a world of command functions never before accessible to O Gauge railroaders. With the addition of the DCS Remote Control System (including a DCS remote handheld and Track Interface Unit) users gain many advanced features, including:

- DCS Proto-Speed Control - Establishes desired locomotive speed in scale miles per hour increments via a thumbwheel control and allows operator to set maximum speed and acceleration/deceleration rates
- ProtoSmoke® Variable Output Control - Controls how much smoke each engine outputs and matches smoke to locomotive speed
- Locomotive Lighting Control - Controls locomotive headlights, marker and interior lights, beacon lights, ditch lights, and MARS lights
- Emergency Stop-Single button push stops all Proto-Sound 2.0 trains but does not turn off the power
- One Touch Global Mute/UnMute-Single button mutes or unmutes all DCS-controlled locomotives' user-defined actions, including sound, lights and smoke
- Proto-Dispatch Operation-Public Address-like feature allows users to speak through locomotive speaker during operation
- Proto-Cast-Allows users to play audio recordings through locomotive speaker during operation
- Proto-Doppler Sound Effects Set Up-Users can configure locomotive for Doppler Operation, including setting distance points for Doppler start, repeat, and stop modes
- Independent Volume Control of Engine Sounds, Bell, Horn & Whistle for each Locomotive
- Control up to 50 different DCS-Equipped Locomotives at one time with multiple TIUs
- Proto-Effects™ Set Up-User can select individual Proto-Effects™ operations to be active or inactive, including cab chatter, train wreck sounds, coupler sounds, and wheel clickety-clack sounds
- Direction Control Set Up-User can set initial individual start-up direction (start in forward or reverse) for double-heading operations
- Locomotive Consist Set-up-User can determine locomotive values for consist make-ups, allowing multiple locomotives belonging to a consist to operate together

Service & Warranty Information

How to Get Service Under the Terms of the Limited One-Year Warranty

For warranty repair, follow the instructions below to obtain warranty service.

First, e-mail, write, call or fax an Authorized M.T.H. Service Center in your area or M.T.H. Electric Trains to obtain Repair Authorization. You can find the list of Authorized Service Centers on the M.T.H. website, www.mth-railking.com. Otherwise, contact M.T.H. (at e-mail: service@mth-railking.com; 7020 Columbia Gateway Drive, Columbia, MD 21046; tel: 410-381-2580; fax: 410-423-0009), stating when the item was purchased and describing the problem. If you contact M.T.H., you will be given a return authorization number to assure that your merchandise will be properly handled upon its receipt.

CAUTION: Make sure the product is packed in its original factory packaging including its foam and plastic wrapping material so as to prevent damage to the merchandise. The shipment must be prepaid and we recommend that it be insured. A cover letter including your name, address, daytime phone number, e-mail address (if available), Return Authorization number, a copy of your sales receipt and a full description of the problem must be included to facilitate the repairs. Please include the description regardless of whether you discussed the problem with a service technician when contacting the Service Center or M.T.H. for your Return Authorization.

Limited One-Year Warranty

All M.T.H. products purchased from an Authorized M.T.H. Train Merchant are covered by this warranty. See our website at www.mth-railking.com or call 1-888-640-3700 to identify an Authorized M.T.H. Train Merchant near you.

M.T.H. products are warranted for one year from the date of purchase against defects in material or workmanship, excluding light bulbs pick-up rollers and traction tires. We will repair or replace (at our option) the defective part without charge for the parts or labor, if the item is returned to an Authorized M.T.H. Service Center or M.T.H. Electric Trains within one year of the original date of purchase. This warranty does not cover damages caused by improper care, handling, or use. Transportation costs incurred by the customer are not covered under this warranty.

Items sent for repair must be accompanied by a return authorization number, a description of the problem, and a copy of the original sales receipt from an Authorized M.T.H. Train Merchant, which gives the date of purchase. If you are sending the item to M.T.H., call 410-381-2580, fax 410-423-0009, or e-mail the Service Department at service@mth-railking.com to obtain a return authorization number. If you are sending this product to an Authorized Service Center, contact that Center for their return authorization.

This warranty gives you specific legal rights, and you may have other rights that vary from state to state.

Service Department
M.T.H. Electric Trains
7020 Columbia Gateway Drive
Columbia, Maryland 21046-1532