

TINPLATE TRADITIONS[®]

By M.T.H. Electric Trains[®]

TINPLATE TRADITIONS[®] 200 Series Crane Car OPERATING INSTRUCTIONS

Thank you for purchasing the TINPLATE TRADITIONS[®]
200 Series Crane Car by M.T.H. Electric Trains[®].

This Tinplate model combines the designs of
yesteryear with the quality and craftsmanship of
today's M.T.H. products.



LUBRICATION

Use a light household oil for lubrication. Apply oil sparingly, using a toothpick or small applicator. Add a drop of oil to the axle holes in the front and rear of each wheel (see photo below). Wipe away excess oil with a cotton swab.

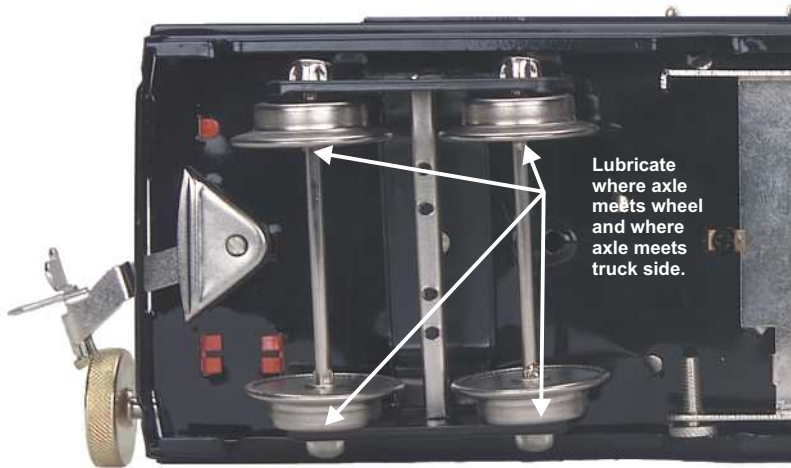

CRANE OPERATION

The 200 Series Operating Crane Car has three control knobs in the rear of the model. These three knobs control the rotation of the crane, raising/lowering of the hook and raising/lowering of the boom.

Please refer to the sketch below for operating instructions.

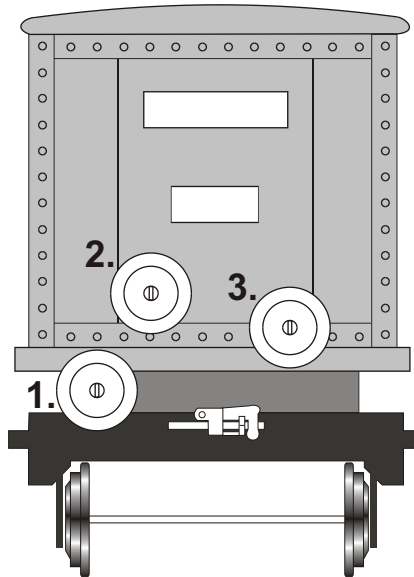

(Rear View of the 200 Series Crane Car)

1. Rotate this knob clockwise to turn the boom to the left.
Rotate this knob counterclockwise to turn the boom to the right.
2. Rotate this knob clockwise to lower the hook.
Rotate this knob counterclockwise to raise the hook.
3. Rotate this knob clockwise to lower the boom.
Rotate this knob counterclockwise to raise the boom.